

Product Manual and Reference Guide



NeXGen™ CCU Series

Capacitor Control Receiver

Model CCURX

Version 1.0 Revision C

Table of Contents

Section	Heading	Pages
1	About This Product Manual	5
2	Technical Support	5
3	Safety Information	6
4	Product Overview	6
5	Feature Set	7
6	Technical Specifications	8 - 17
7	Installation and Power Up	18 - 22
8	Communications	22 - 26
9	Mode Switch Functionality	27 - 28
10	Jumper Settings	29 - 30
11	Autonomous Control Functionality	31 - 35
15	DNP Device Profile	36 - 42
	MODBUS Register Map	42 - 43
A	Troubleshooting	62
B	Default Parameter Settings Matrix	63



SAFETY PRECAUTIONS AVOID INJURY

Safeguards are designed into this instrument to protect operators and maintenance personnel from most hazards during instrument operation. However, certain safety precautions must be taken by the operator and all personnel to avoid injury as well as damage to the instrument.

Carefully observe the following safety precautions before and during installation and operation on the instrument. Failure to comply can result in death, severe personal injury, and instrument damage.

- **ALWAYS** follow safety procedures listed in the instructions
- **ALWAYS** follow all locally approved procedures, codes and safety practices when working around high voltages and when testing, installing and/or operating this instrument
- **ALWAYS** wear approved safety gear when operating power equipment.
- **ALWAYS** wear approved ear protection when operating power equipment.
- **ALWAYS** wear approved eye protection when operating power equipment.
- **ALWAYS** insert power plug into properly grounded receptacle to avoid electrical shock
- **NEVER** disconnect any components unless area is known to be nonhazardous
- **NEVER** wear loose clothing or jewelry that may catch moving parts or circuits in the instrument.
- **NEVER** alter, modify or misuse the instrument
- **NEVER** rely on absence or function of LED indicators for presence of high voltages. Always establish a visible disconnect. Failure to follow proper safety practices can result in contact with high voltage which can cause death, or severe personal injury.
- **IMPORTANT** – These instructions are not a substitute for adequate training and experience in safety procedures. These instructions are intended for use by competent personnel who are trained and understanding of proper safety procedures.

COPYRIGHT NOTICE

Advanced Control Systems Corporation/Telescada has prepared this manual for use by Telescada personnel, Telescada Authorized Representatives and Telescada Customers as a guide to proper installation, configuration, operation, and maintenance of this Telescada product. The drawings and specifications contained herein are the property of Advanced Control Systems Corporation/Telescada and shall neither be reproduced in whole or in part without Advanced Control Systems Corporation/Telescada's prior written approval nor be implied to grant any license to make, use or sell equipment manufactured in accordance herewith. Advanced Control Systems Corporation/Telescada reserves the right to make changes without notice in the specifications and materials contained herein and shall not be responsible for any damages (including consequential caused by reliance of the materials presented. Please consult the factory for the most recent documents pertaining to all products.

© Advanced Control Systems Corporation / Telescada, 2015. All rights reserved

GENERAL INFORMATION

Advanced Control Systems Corporation/Telescada is dedicated to designing, developing and producing the highest quality hardware and software for Utility applications. Our goal is to provide our customers with reliable products and solutions that simplify and enhance day to day operations. We use state-of-the-art electronics to get the highest performance at the lowest cost. Our principal resources are our people and the support and confidence of our customers.

WARRANTY

Advanced Control Systems Corporation/Telescada warrants its products to operate within specifications under normal use and services for a period of one year from the date of shipment. Components products, spares, replacement parts and repairs are warranted for 90 days. Software is thoroughly tested and thought to be functional. It is supplied "as is" with no warranty of any kind covering detailed performance. Accessory products not manufactured by Advanced Control Systems Corporation/Telescada are covered by the original equipment manufacturer's warranty only. In exercising this warranty, Advanced Control Systems Corporation/Telescada will repair or at its option, replace, any product returned to the customer service department or an authorized service facility within the warranty period, provided that the warrantor's examination discloses that the product is defective due to workmanship or materials and has not been caused by misuse, neglect, accident or abnormal conditions or operations. The purchaser is responsible for the transportation and insurance charges arising from the return of products to the servicing facility. Advanced Control Systems Corporation/Telescada will return all in-warranty products with transportation prepaid. This warranty is in lieu of all other warranties, expressed or implied, including but not limited to any implied warranty of merchantability, fitness, or adequacy for any particular purpose or use. Advanced Control Systems Corporation/Telescada shall not be liable for any special, incidental or consequential damages whether in contract, or otherwise.

Revision History

VERSION	REVISION	DATE	AUTHOR	COMMENT
1.0	-	8-5-13	DRC	Original Release
	A	11-21-14	CWM	Technical Specifications Update
	B	2-26-15	CWM	Updated for Revision E PCB
	C	11-23-15	CWM	Technical Specifications Update

1. About This Product Manual

Purpose

This User's Manual provides a detailed technical overview of the Telescada NeXGen™ CCURX. It is to be used to communicate the features, functionality and operation of the NeXGen™ CCURX.

Additional Reference Documentation

Telescada NeXGen™ CCURX Users will also need to refer to the Telescada NeXGen™ NGC (NeXGen™ Configurator) Users Manual to assist with programming and interrogation of Telescada NeXGen™ instruments

- *Telescada NeXGen™ NGC User's Manual*

2. Technical Support

Answers to questions concerning the installation, operation, maintenance and use of Advanced Control Systems Corporation/Telescada products is available from our technical service department:

Telescada
 35 Corporate Park Drive
 Pembroke, Massachusetts, USA 02359
 Telephone: 781-829-9228 08:00 to 17:00 Eastern Standard Time
 FAX: 781-829-9875
 e-mail info.desk@telescada.com

3. Safety Information

When reading this manual, pay particular attention to



Denotes an imminent hazard which may result in moderate or severe injury



Denotes an environment hazard which may result in moderate or severe injury



Denotes a condition which may result in instrument damage



Highlights special or important information

4. Product Overview

Classic design, with contemporary functionality, the Telescada NeXGen™ CCURX Capacitor Control Expandable Radio Receiver is a powerful, flexible and expandable solution for wireless distributed capacitor control.

The NeXGen™ CCURX highly sensitive double superheterodyne VHF receiver allows the NeXGen™ CCURX to operate via classic broadcast AFSK radio tones. The NeXGen™ CCURX decodes AFSK tones that comply with Fisher Pierce 11-Bit, and REMS 101/102 Legacy Protocols

When it's time to go with 2-Way communications, the NeXGen™ CCURX provides users with a core of 8 configurable analog and 4 digital status inputs for monitoring and a dedicated AC line voltage measurement input accurate to +/- 1% @ 117VAC. The NeXGen™ CCURX can also transmit data from an IED (intelligent electronic device), or smart meter via its Ethernet or RS-232 serial communications links.

With the installation of a 2-Way transceiver and the NeXGen™ CCURX communicates with distributed capacitor control SCADA programs via DNP3 or MODBUS protocols.

5. Feature Set

5.1. Features Overview

- **Analog Inputs**
 - 6 (six) 0-5VDC Analog Inputs for External Voltage/Current Transducers
 - 2 (two) 0-10VAC Analog Inputs for External Neutral Current Sensors
 - 1 (one) Single Phase AC Line Voltage Input
 - +/-1% accuracy at 120VAC
 - Data Recording on Each Input
- **Digital Inputs**
 - 4 (four) Optically Isolated Digital Inputs
 - Data Recording on Each Input
- **Control Relays**
 - 2 (two) Rated 30A at 240 VAC
 - Configurable OPEN/CLOSE timing
 - Configurable Safety Timer
 - Configurable OPEN/CLOSE Local Delay
 - Digital Counter with Data Recording
 -
- **Temperature Sensor (Optional)**
 - TTT-1 Ambient Temperature Transducer
- **Communications**
 - 1 (one) USB (B-Type) Comm. Port (Local)
 - 1 (one) RS-232 COM1 Comm. Port (Local or remote)
 - 1 (one) Ethernet Communication Port
 - Legacy AFSK Tone Protocols
 - DNP3.0 / MODBUS Protocols
 - Integrated VHF AFSK Tone Receiver
 - High Sensitivity Double Superheterodyne
 - -113 dBm Input Sensitivity
 - VHF Frequency Programmable
 - 12.5Khz
 - RSSI Indicator)
- **Power Supply & Physical Form Factor**
 - 120 VAC Input
 - 8.12" x 8.12" x 4.0" NEMA 4X Enclosure
 - 4 or 6 Stab Socket or Pole Mount Options
- **Local Controls & Feedback Indicators**
 - High Brightness External RED/GREEN/YELLOW State Indicator LED
 - High Brightness External Fault LED (YELLOW)

- Local TRIP / CLOSE Pushbuttons (Local mode)
- Local SCADA Lock-Out Switch (Local mode)
- Optional Mechanical Counter (counts close operations)

5.2. Features Detail

- The low cost of the NeXGen™ CCURX allows for economic use of flexible capacitor control automation throughout existing 1-way VHF (AFSK) distribution systems.
- The integrated high sensitivity double superheterodyne VHF receiver module in the NeXGen™ CCURX allows for expansion of the 1-way AFSK receiver system beyond traditional geographic limits
- When it's time to upgrade the existing 1-way Capacitor Control system to a 2-way scheme, you simply add your choice of 2-way transceiver and reprogram the NeXGen™ CCURX to communicate via native DNP protocol.
- Remote Communication serial ports are Ethernet RS-232 or RS-485 type and configurable for any manner of UHF/VHF/900 MHz, or Cellular Communications.
- Local interrogation and programming of the NeXGen™ CCURX via dropdown lists in the Windows® Based NeXGen™ NGC Utility software requires no programming knowledge.

6. Technical Specifications

6.1. Analog Inputs

- 6 (six) analog inputs
 - 0-5VDC nominal
 - Current input with adapter board
 - Data recording on each channel
 - Statistical data recording (min – max – average)
 - Event reporting on each channel
 - Accuracy – 0.1% of full scale
 - Analog connectors have +5VDC and VBatt+ (13.8VDC) for sensor loop power
 - 20 K ohm input impedance – ESD protected

- 2 (two) analog inputs
 - 0-10VAC
 - Data recording on each channel
 - Statistical data recording (min – max – ave)
 - Event reporting on each channel
 - Accuracy – 0.1% of full scale
 - Analog connectors have +5VDC and VBatt+ (13.8VDC) for sensor loop power
 - 20 K ohm input impedance – ESD protected

- External Temperature Sensor
 - Telescada P/N TTT-1
 - Typical error @ 25 deg. C (77 deg. F) of .5 deg. C (~ 1 deg. F). Worst case 1 deg. C. Rated over -40 deg. C (-40 deg. F) to 125 deg. C (257 deg. F) with a max error over that range of 3 deg. C.

6.2. Digital (Status) Inputs

- 4 (four) Digital Inputs
 - Data recording on each channel
 - Event reporting on each channel
- Wetted (pulled up to 13.8VDC by 2.7K ohms) - Appropriate for dry relay contacts
- 4 DI channels configurable for 2 KYZ inputs
- Per point configurable for Form A, B, C or transition accumulators
- Digital timing input accuracy of +/-1 ms
- Report limiting for the accumulators
- Digital Inputs are internally pulled up to 13.8 VDC via 2.7K ohms
- Digital inputs are ESD protected

External Digital Inputs

Connector pins labeled STATUS IN 0, 1, 2, 3 are external digital inputs. These 4 inputs are protected from surges and pulled up to +13.8 VDC by 2.7K ohm resistors. The NeXGen™ CCURX uses these inputs as state indicators, and in pairs as KYZ inputs for pulse counters. Inputs 0 (Z), 1 (Y) and GND (K) form one of 2 KYZ inputs. Inputs 2 (Z), 3 (Y) and GND (K) combine to form a second KYZ input. KYZ inputs count only when Z is pulled low followed by Y being pulled low when Z is high. KYZ inputs are used to connect meter pulse outputs to the NeXGen™ CCU.

Note: To insure a state change is counted each status input must pull down below 1 volt with respect to the “K” (GND) input. A closed set of relay contacts with less than 200 feet 22 AWG of wire will create this condition.

6.3. Capacitor Bank Control Relays

- 1 (one) TRIP Control Relay
- 1 (one) CLOSE Control Relay
 - SPST semi-sealed, Rated for 30A @ 240 VAC
 - Configurable OPEN/CLOSE contact closure time
 - Configurable Safety Timer (Close Lockout)
 - Digital Counter with Data Recording

6.4. Autonomous Control Capabilities

The NeXGen™ CCURX can execute standalone capacitor control functions in the absence of 2-way communications, or as a back up to distributed (SCADA) control via one of the following methods

- Autonomous Voltage Control
- Autonomous Temperature Control
- Autonomous Time of Day Control

Capacitor Bank Control Relays

- 1 (one) TRIP Control Relay
- 1 (one) CLOSE Control Relay
 - SPST semi-sealed, Rated for 30A @ 240 VAC
 - Configurable OPEN/CLOSE contact closure time
 - Configurable Safety Timer (Close Lockout)
 - Digital Counter with Data Recording

ATTENTION The programmable relay timer parameter setting in Telescada NeXGen™ NGC Configuration Software only applies to 1-way settings using legacy tone receiver protocols. When using DNP, the Control Relay TRIP and CLOSE duration is determined by the DNP master and specified in the DNP message.

6.5. Communications

• Remote Communications

- 1 (one) Ethernet communication port
- 1 (one) RS-232 serial communication port
- Configurable baud rates up to 38.4kbps
- Connectors for serial communications ports are RJ-12 3-wire type
- DNP3.0, Modbus RTU / ASCII Protocols installed and Configurable

• Local Communications

- Server assignable ports – 2 servers can operate simultaneously
- 1 (one) USB B-Type serial maintenance port for “LOCAL” interrogation, NeXGen™ CCURX database programming and data transfer.
- 1 (one) Proprietary RS-232 (RJ45) Firmware port for loading firmware
- Configurable USB1 and IED1 baud rates up to 38.4kbps
- Connector for IED1 port is 3-wire RJ-12 type
- Interrogation, database programming and data transfer via USB1 or IED1 is achieved using Telescada NeXGen™ NGC Utility Software

6.6. Power Supply

- The NeXGen™ CCURX is powered by an internal transformer from a 120VAC external supply – line voltage.
- Input power – 85 - 135 VAC (120 VAC Nominal)
- Always on when power is applied
- Short circuit protection via resettable fuse in 120 VAC circuits
- 3.3 VDC, 5 VDC and 13.8 VDC operating power supplies
- 13.8 VDC is brought out to “+” and “-“ terminals to power external communications devices, e.g. radios, modems, ...
- 10 W maximum input supply draw

6.7. Processor and Memory

- The Core module processor is the R3000 operating at 22 MHz.
- Memory:
 - FLASH: 1MB
 - SRAM: 512k
 - Serial Flash Memory: 4MB
 - Battery Backed RTC (Real Time Clock)

- Watchdog timer

6.8. Physical & Environmental

• Physical Specifications

- The NeXGen™ CCURX is housed in a NEMA 4 protective polycarbonate enclosure 8.12"H x 8.12"W x 4.38" D
- 4-Stab Socket Mount
- 6-Stab Socket Mount
- Utility Pole Bracket Mount
- Multiple LED status indicators – including sealed external LED
- Standard USB B-Type for local interrogation and configuration
- Standard RJ-12 connectors for communications
- Each COM port includes RX and TX lights
- #14 Compression Terminal Blocks provided for field terminations -analogs, status inputs and power
- All field termination locations are clearly labeled on the PCB and enclosure cover

• Environmental Operating Conditions

- Operating Temperature range: -40° to +60°C
- Storage Temperature: -40° to +60°C
- Humidity: 5% to 95% Non-condensing

6.9. PCB Physical Overview

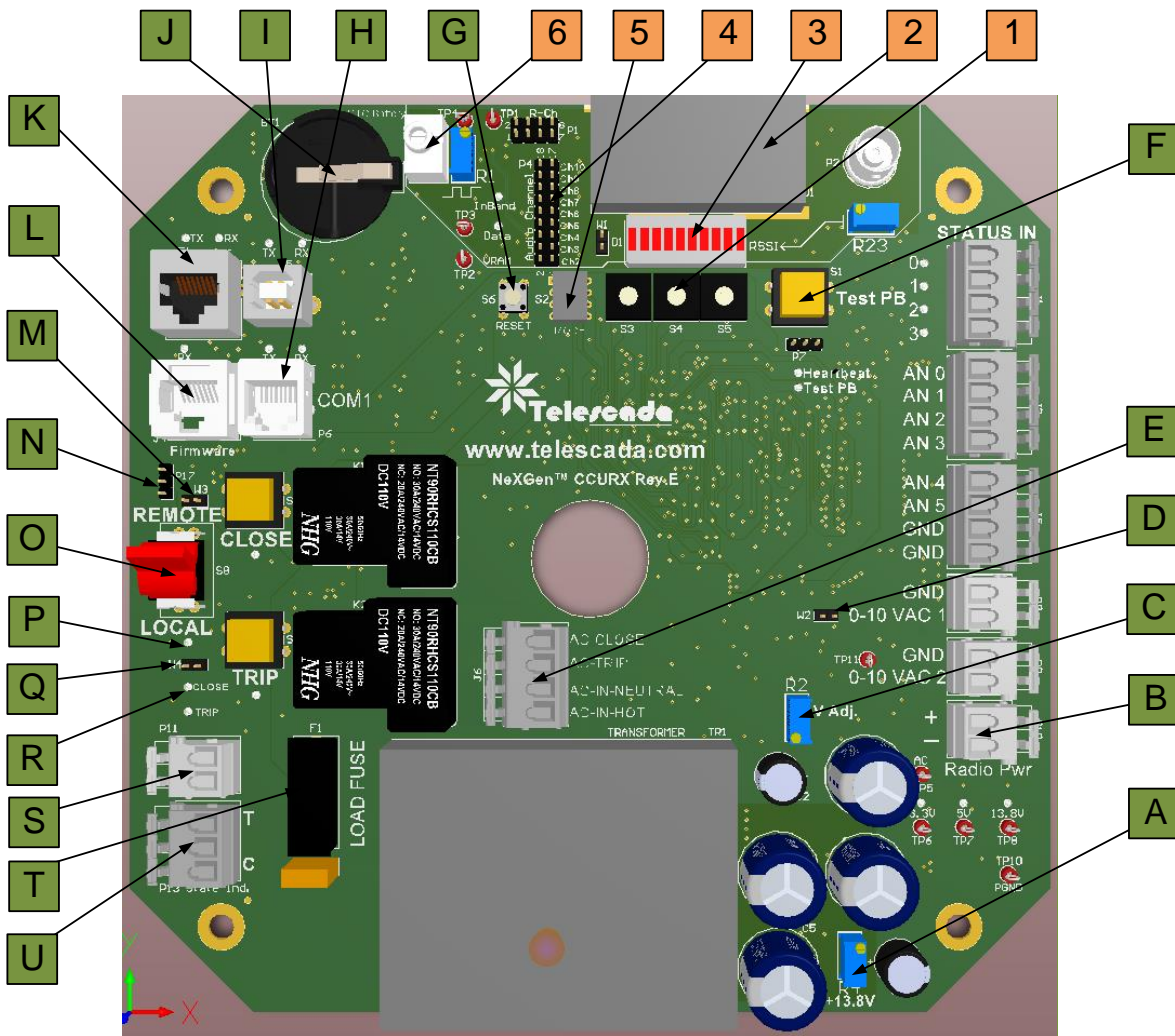

- A. **RADIO POWER ADJUST:** This trimmer allows for the adjustment of 12VDC nominal power for external radio/modem transceiver.
- B. **RADIO POWER TERMINAL BLOCK:** This terminal block is for the connection of the external radio/modem transceiver.
- C. **LINE VOLTAGE MEASUREMENT CALIBRATION:** This trimmer allows for the calibration of the internal line voltage measurement dedicated analog channel.

ATTENTION The line voltage measurement analog controls the autonomous voltage override function of the NeXGen™ CCURX. Proper

calibration of this analog to line voltage will assure proper operation. Calibration is accomplished with NeXGen™ NGC Configurator software.

- D. **ANALOG 6 JUMPER:** This jumper, when installed selects 0-10VAC input for Analog 6. Removing the jumper conditions the input for Analog 6 to 0-5VDC.
- E. **POWER:** This 4 connector group is where the power is applied, and the “TRIP” and “CLOSE” control outputs are available. The “TRIP” and “CLOSE” connection points are connected to the “AC-IN-HOT” by the actuation relays. The NeXGen™ CCURX is designed to operate from a standard line voltage of 120 VAC. The bottom connector is labeled with “AC-IN-HOT.” It should be connected to the high side of the single phase line. The next connector towards the top is labeled “AC-IN-NEUTRAL” and should be connected to the neutral side of the line. If an earth ground is required or desired, any of the 4 mounting screws or connectors labeled GND can be used.
- F. **TEST PB:** The test pushbutton is used to send DNP messages via the COM1 serial port. The Test pushbutton has 2 LEDs associated with it. The first LED is labeled Heartbeat. The heartbeat LED blinks once per second when the firmware is working properly. The second LED is labeled Test PB which lights up whenever the Test Push Button is depressed.
- ATTENTION** If the test pushbutton is held closed for more than 10 seconds a new database will be loaded into the NeXGen™ CCURX.
- G. **RESET BUTTON** This small white button resets the processor which restarts the firmware. As the firmware starts it reads the NeXGen™ CCURX database and the state of the user controls. The database programmed into the NeXGen™ CCURX is stored in non-volatile memory and is not be modified by a reset.
- H. **COM1:** COM1 is a serial port that typically operates at 9600 bits per second, 8 bit data, no parity, and 1 stop bit. (9600, 8,N,1). This port can be used to connect to a digital radio, a cellular modem or directly to a computer. This port is used to configure the operation of the NeXGen™ CCURX. Telescada’s NGC configuration software is required for instrument configuration.
- I. **USB1:** This USB Type B connector provides for local interrogation and configuration of the NeXGen™ CCURX. Telescada’s NGC configuration software is required for instrument configuration.

- J. **RTC BATTERY BACK UP:** This 3VDC lithium battery provides back up power to the NeXGen™ CCURX real-time clock and processor RAM. The NeXGen™ CCURX consumes no battery power when running on 120VAC. Storage life of the battery is approximately 10 years. Replacement battery is Panasonic CR2032 or equal.
- K. **ETHERNET PORT:** This Ethernet port can be used for distributed or remote communications.
- L. **FIRMWARE PORT:** This port is used for uploading new firmware to the NeXGen™ CCURX.
- M. **LOCAL CLOSE DELAY OVERRIDE: W3** is a jumper that allows the CLOSE switch to operate the close relay immediately. If the jumper is removed pushing the CLOSE pushbutton sends a signal to the processor and starts the 1 minute close delay (See CCURX customer database for actual delay). If power was recently applied, a yellow light or both the close and trip LEDs will blink until the close relay activates. After 1 minute the CLOSE relay will click and the state indicator LED will be solid red.
- N. **P17:** A jumper must be installed if local control is to be used. Jumping the top 2 pins of P17 defeats the Safety timer. The TRIP and CLOSE relays will operate immediately in conjunction with the TRIP and CLOSE switches. Jumping the bottom 2 pins causes the safety timer to be enforced. The safety timer can be configured using NGC, a software program available from Telescada used to configure all the NeXGen™ series of instruments and controls.
- CAUTION** Always confirm your jumper settings to ensure that the safety timer is enforced prior to deploying the NeXGen™ CCURX.
- O. **REMOTE/LOCAL SWITCH:** This red toggle switch chooses between the local or remote mode. When the instrument is in the local mode an LED near the LOCAL label flashes. When the NeXGen™ CCURX is in the local mode, signals from SCADA will not operate the NeXGen™ CCURX.
- P. **LOCAL MODE LED:** This RED LED will flash at a rate of 100ms when the control is in LOCAL mode. It serves as a reminder for the operator to switch the control back to remote mode to enable communications with SCADA.
- Q. **LOCAL TRIP DELAY OVERRIDE: W4** is a jumper that allows the TRIP switch to operate the trip relay immediately. If the jumper is removed pushing the TRIP pushbutton sends a signal to the processor and starts the 1 minute trip delay (See CCURX customer database for actual delay).

If power was recently applied, a yellow light or both the close and trip LEDs will blink until the TRIP relay activates. After 1 minute the TRIP relay will click and the state indicator LED will be solid green

- R. INTERNAL STATE INDICATOR:** Two board-mounted LEDs, labeled Trip and Close and located below the red toggle switch, are used as internal state indicators. These LEDs are connected in parallel with the external indicator. Both LEDs are lit up after power to the control has been interrupted (the external indicator would show amber).
- Both LEDs illuminated => power has been interrupted
 - Red LED illuminated => Control has processed a close command and has detected 120 VAC on the CLOSE socket contact
 - Green LED illuminated => Control has processed a Trip command and has detected 120 VAC on the Trip socket contact
 - Green LED flashing => indicates safety timer lockout for a Close operation is in force
 - Red flashing LED => An error has occurred. It is possible to induce this state by simultaneously pushing the Trip and Close buttons in local mode. When this state occurs either wait for the safety timer to expire or reload the NeXGen™ CCU database by continuously pushing the Test pushbutton for more than 10 seconds.
- S. MECHANICAL COUNTER TERMINAL BLOCK:** This terminal block provides connection to the optional mechanical operations counter,
- T. LOAD FUSE:** The load, both TRIP and CLOSE, are switched by the 2 power relays, and are fused by the load fuse. The fuse is a 5 X 20 mm cartridge and can be purchased in various sizes up to 25 amps. An open load fuse switch does not send power or signals to the capacitor switch at the top of the pole.



Always use caution removing and replacing the load fuse cartridge.

- U. EXTERNAL INDICATOR CONNECTOR:** The external LED indicator is connected here. Not all NeXGen™ CCURX controls are shipped with an external indicator. There are 3 positions in this connector group. The center connector is the common point and the black wire of the state indicator LED should be plugged in here. The red wire from the state indicator LED should be plugged into T (trip) connection if the utility wants a red light to indicate a trip condition. In this, case the green wire from the indicator should be connected to C (close) position. Both wires must be connected so that an error indicator (orange color from the LED) is possible. (Note: The state indicator LED is mounted on the exterior of the

NeXGen™ CCURX enclosure not on the printed wiring board. It is not shown in Figure 1.)

1. **TS11 ADDRESS:** Three address wheels convey the tone control ADDRESS to the NeXGen™ CCURX processor. This address, read from left to right as 3 octal numbers, is used in tone control decoding, but not for DNP. The highest address possible is 777 octal (511 decimal). Set the address wheels to the desired address and then tap the small, white reset button. As the firmware resets, the displayed address will be read and become the operative tone control address.

REMS ADDRESS: Three address wheels convey the tone control ADDRESS to the NeXGen™ CCURX processor. This address, read from left to right as 3 hex numbers, is used in tone control decoding, but not for DNP. The highest address possible is FFF hex (4095 decimal). Set the address wheels to the desired address and then tap the small, white reset button. As the firmware resets, the displayed address will be read and become the operative tone control address.

2. **VHF RECEIVER MODULE:** The receiver module is labeled with the radio frequency it is designed to receive. The receiver's frequency must match the frequency that the utility is broadcasting.
3. **RSSI INDICATOR:** The RSSI (Receive Signal Strength Indicator) is an array of LEDs that indicates the intensity of the radio frequency signals at the receiver's frequency. The RSSI LEDs only indicate the presence of radio frequency signals. It does not convey any information about the audio tone modulation level. The RSSI indicator is factory set so that 5 LEDs are illuminated when the RF signal detected has a level of -90 dB. Each LED has a weight of about 3 dB.
4. **AUDIO CHANNEL SELECT:** This 18 pin header is used to select the audio channel on which the utility would like the NeXGen™ CCURX to operate. If no jumper is plugged on to the header, channel 1 is selected. Connecting across the lowest pair of P4 pins selects audio channel 2. The red arrow points to the location for audio channel 8
5. **MODE DIP SWITCH:** The NeXGen™ CCURX Mode DIP Switch is a small black with white slides 4-position DIP switch. The mode switch allows for a customer specific default program to be loaded into the NeXGen™ CCURX at time of initialization, or reset.
6. **AUDIO INPUT JACK:** A 3.5mm stereo jack provides direct input to the NeXGen™ CCURX VHF receiver. The jack can be used to capture and record received VHF audio for diagnostic purposes.

7. Installation and Power-Up

ATTENTION

For accurate and reliable operation of your NeXGen™ CCURX the following practices and recommendations must be considered at all times. The instrument warranty may be null and void if you do not follow these practices and recommendations. If you have any concerns, do not hesitate to contact Telescada.

CAUTION

Do not attempt the installation of your NeXGen™ CCURX if it has been dropped, damaged or the packaging indicates it may have been dropped or damaged.



Follow all locally approved procedures, codes and safety practices when working around high voltages and when testing, installing and/or operating this instrument. Based upon the instrument configuration the instrument power supply **MAY BE UNGROUNDED**.

7.1. Instrument Connection Overview

The NeXGen™ CCURX is supplied by the factory in either a 4/6 stab socket mount, or utility pole mount enclosure style. The following wiring diagrams describe the most popular wiring styles; however the NeXGen™ CCURX can be wired to meet the specific needs of the individual utility.

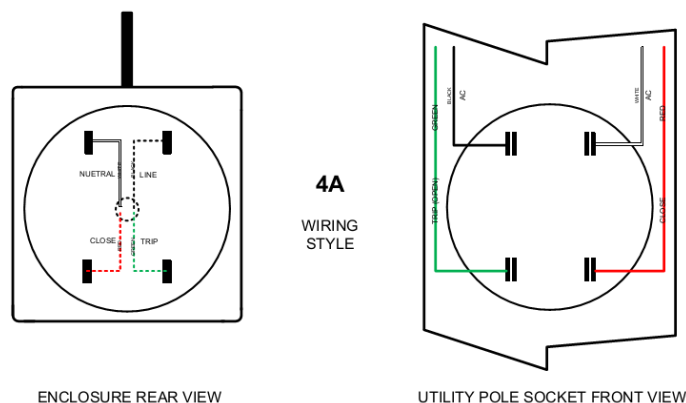

FIG. 4 NeXGen™ CCURX 4A Wiring Diagram

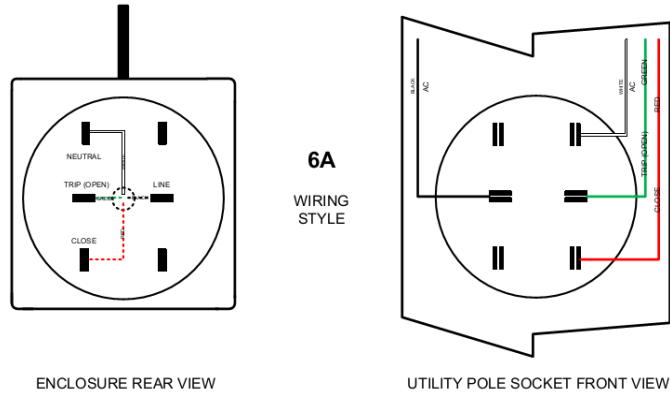

FIG. 5 NeXGen™ CCURX 6A Wiring Diagram

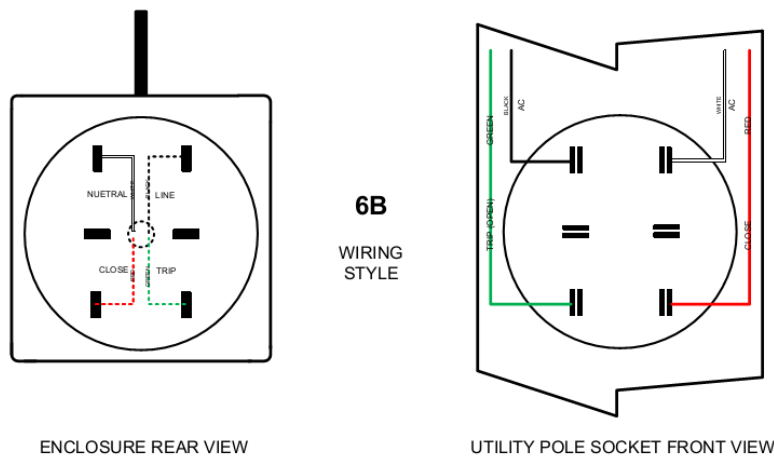

FIG. 6 NeXGen™ CCURX 6B Wiring Diagram

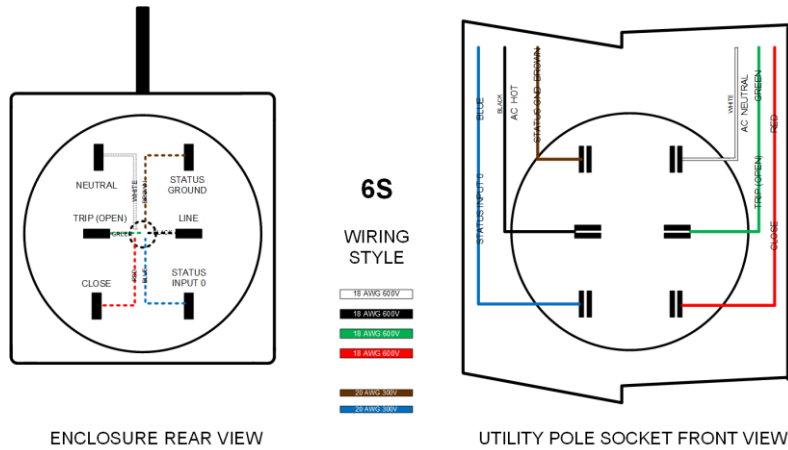

FIG. 7 NeXGen™ CCURX 6S Wiring Diagram

7.2. Installation Environment

The NeXGen™ CCURX installation must be acceptable to the regulatory authority having legal jurisdiction over the installation. The NeXGen™ CCURX polycarbonate enclosure is designed for outdoor use.

The NeXGen™ CCURX employs spring based compression terminals for all inputs.

CAUTION Ensure that all input wires are securely contained in the appropriate spring clamps prior to powering up the instrument.



Follow all locally approved procedures, codes and safety practices when working around high voltages and when testing, installing and/or operating this instrument. Based upon the instrument configuration the instrument power supply **MAY BE UNGROUNDED**.

7.3. Input Power Supply

- **Input Power Configuration**

The NeXGen™ CCURX is powered by an on board transformer and multiple DC power supplies. Input voltage for the NeXGen™ CCURX is 85 – 135 VAC (120 VAC nominal). The NeXGen™ CCURX is always-on when powered, i.e. there is no power switch.

CAUTION

Make sure that the external AC power supply is within the proper range for the instrument and polarity of the wiring matches that indicated on the terminal block.

- **Transient Voltage Protection**

The NeXGen™ CCURX instrument is protected by a metal-oxide varistor located between the 120VAC input HOT and NEUTRAL lines. The varistor is located between the NeXGen™ CCURX instrument enclosure and the socket adaptor ring.

DANGER

A catastrophic overvoltage event may destroy the MOV and require it to be replaced. Remove the NeXGen™ CCURX from service and replace the MOV.

- **NeXGen™ CCURX Control Resettable Fuse**

The NeXGen™ CCURX control circuit board is protected by a resettable fuse located on the CCURX printed circuit board.

DANGER

The input voltage is connected to the internal power supplies through a resettable fuse. If the input current exceeds the fuse current rating the fuse will open. Resettable fuses take some time to recover. Remove the input voltage and allow 30 minutes for fuse recovery.

- **Grounding**



In many instances the NeXGen™ CCURX instrument is not connected to an earth ground. If a ground connection is desired, connect the NeXGen™ CCURX enclosure to earth ground using a braided cable or heavy solid copper conductor. When making ground connections ensure that all grounding surfaces are free of dirt, residue and corrosion. The ground wire must be the largest gauge of all wires used for field termination. A 12 AWG green and yellow wire is recommended. For spring based compression terminals the maximum wire gauge is 12 AWG.

8. Communications

8.1. Serial Connections

The NeXGen™ CCURX has 3 serial interfaces for local and remote communications. Serial interfaces are RS-232 type (1 USB on PCB revisions E and higher). Serial interfaces are configured using the Telescada NeXGen™ NGC Configuration Software.

The Local, IED1 and COM1 serial interfaces on the NeXGen™ CCURX printed circuit board are standard 6 position modular jacks (RJ12). The mating 6 position modular plug: Tyco Electronics P/N 5-555176-3, or equal.

ATTENTION When using remote serial communications, such as digital radio, digital cellular, digital fiber optic transceivers communications devices may be plugged into the Local Port or IED ports. Serial communications is programmed using the configuration software, NGC. Most remote communications devices are plugged in to the COM1 port.

- **Local/Programming/Serial Port**

The NeXGen™ CCURX Serial port programming functions are accomplished using the Telescada NeXGen™ NGC Configuration Software and a corresponding TAC-01 series programming cable. PCB Revision E and higher have a USB B-Type connector that allows for a standard USB B-Type to A-Type cable. The TAC-01 cable is terminated with a 6 pin modular plug (RJ-12) on one end and a DB9

connector on the other. The NeXGen™ CCURX Local/Programming Port is labeled as COM1.

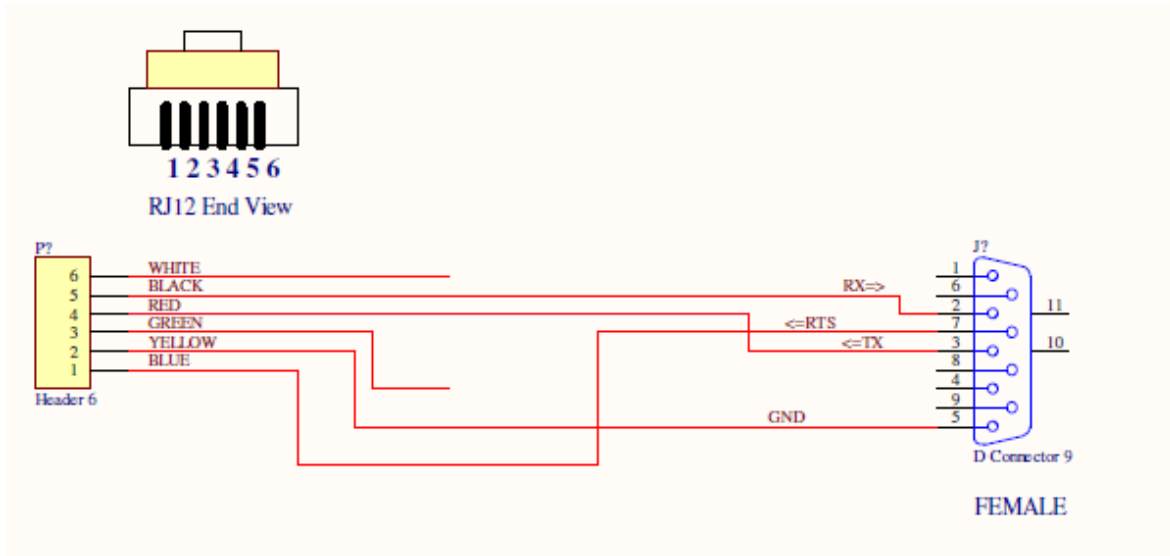

FIG. 8 NeXGen™ TAC-01 Series Local Cable

The NeXGen™ CCURX Local port is a three wire implementation using a modular RJ-12 jack with RS-232 signal levels. This port defaults to 9600 baud 8,N,1. The TAC-01 includes a 4th wire, but it is not used by the CCURX. A local programming terminal, (a.k.a. laptop computer), is typically connected to COM1. This port can also be used as a digital radio interface or a modem port if the modem is programmed so that it does not require AT commands or hardware handshaking lines. Note: Looking into the connector, Pin 1 is on the right.

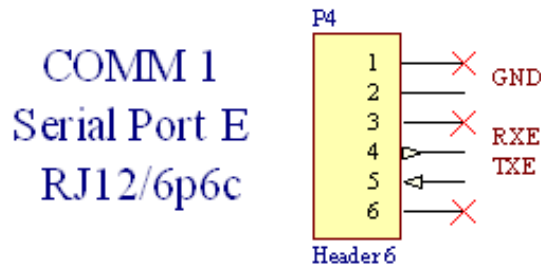

FIG. 9 NeXGen™ CCURX Local Port Pin-Out (for PCB revision A through D)

IED Communications

8.1.1 IED1 Port – RS-232

The IED 1 port is a 3 wire implementation using a modular RJ-12 jack with RS-232 signal levels. IED 1 Port defaults to 9600 baud, and no hardware handshaking, but parameters to change its baud rate can be set using Telescada NeXGen™ NGC Configuration Software.

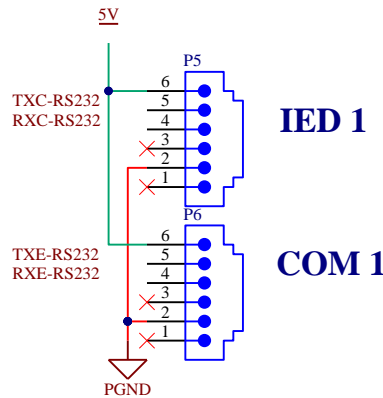

FIG. 10 NeXGen™ CCURX IED Port 1 Pin-Out

• Test and Reset Push Buttons

The NeXGen™ CCURX Test pushbutton is used for remote field diagnostics and instrument configuration. The NeXGen™ CCURX Test Pushbutton is a large square yellow button located on the right side of the PCB and labeled as “TEST PB”.

The NeXGen™ CCURX Processor “Reset” Pushbutton is used to reset the instrument’s processor. The reset button is a small white round momentary switch located on the center left of CCURX printed circuit board.

8.1.2 Test Pushbutton Functionality

The NeXGen™ CCURX Test Pushbutton, when depressed momentarily, will send a message from the NeXGen™ core processor, to the Local/Serial Port. This message can be used to identify the CCURX address.

If the NeXGen™ CCURX is connected to a PC or Laptop running the NGC configuration software, the NeXGen™ core processor will send a message to NGC with the instrument’s programmed address and some configuration information.

ATTENTION

Holding down the Test Pushbutton for 10 (ten) seconds or longer will default the NeXGen™ core processor and reset the instrument address to the corresponding address on the rotary address dials, and sets all parameters to their default setting specified by the Mode DIP switch position.

8.2 General LED Indicators

The NeXGen™ CCURX has a number of LED indicators to quickly visually confirm instrument systems operations and health status.

LED	Location	Color	Description
Heartbeat	PCB - Heartbeat	RED	Indicates normal operation when blinking at 1" (one second) intervals.
Heartbeat	PCB - Heartbeat	RED	Provides 3 short blinks (in one second) at startup
Heartbeat	PCB - Heartbeat	RED	Provides 2" (two seconds) of solid LED ON at soft restart of firmware
Heartbeat	PCB - Heartbeat	RED	Provides 3 short blinks (in one second) during CFD scan for data recording
Test Push Button	PCB - Heartbeat	RED	Indicates the pressing of the Test Pushbutton, and sending a COMM message
Ethernet Tx/Rx	PCB above port	RED/GREEN	Indicates transmission and receipt of communications through Ethernet Port
IED 1 Tx/Rx	PCB above port	RED/GREEN	Indicates transmission and receipt of communications through IED Port
COM1 Tx/Rx	PCB above port	RED/GREEN	Indicates transmission and receipt of communications through COM 1 Port
Programming Rx	PCB above port	GREEN	Indicates receipt of communications through Programming Port
Status	PCB - Status 0 - 3	RED	Indicates status change when pulled to ground
3.3V	PCB - 3.3V	GREEN	Solid green indicates normal operation of 3.3V BUS
5V	PCB - 5V	GREEN	Solid green indicates normal operation of 5V BUS
13.8V	PCB - 13.8V	GREEN	Solid green indicates normal operation of 13.8V BUS
Local	PCB - Below LOCAL	RED	Flashes at 100ms rate when paddle switch is in LOCAL mode

Close	PCB - Below CLOSE button	RED	LED lights when power is applied to relay coil
Trip	PCB - Below TRIP button	GREEN	LED lights when power is applied to relay coil
Close	PCB - next to small CLOSE	RED	State indicator - illuminated when control is in the CLOSE state
Trip	PCB - next to small TRIP	GREEN	State indicator - illuminated when control is in the TRIP state
Close/Trip	PCB - next to Trip/Close	RED/GREEN	Solid red and green upon instrument initialization or loss of power
Close	PCB - Below Small CLOSE	RED	Flashes at 250ms rate when counting down CLOSE delay timer
Trip	PCB - Below Small TRIP	GREEN	Flashes at 250ms rate when counting down TRIP delay timer

9 Mode Switch Functionality

The NeXGen™ CCURX Mode DIP Switch is a small black with white slides 4-position DIP switch at S2 on the CCURX PCB. The mode switch allows for a customer specific default program to be loaded into the NeXGen™ CCURX at time of initialization, or reset.

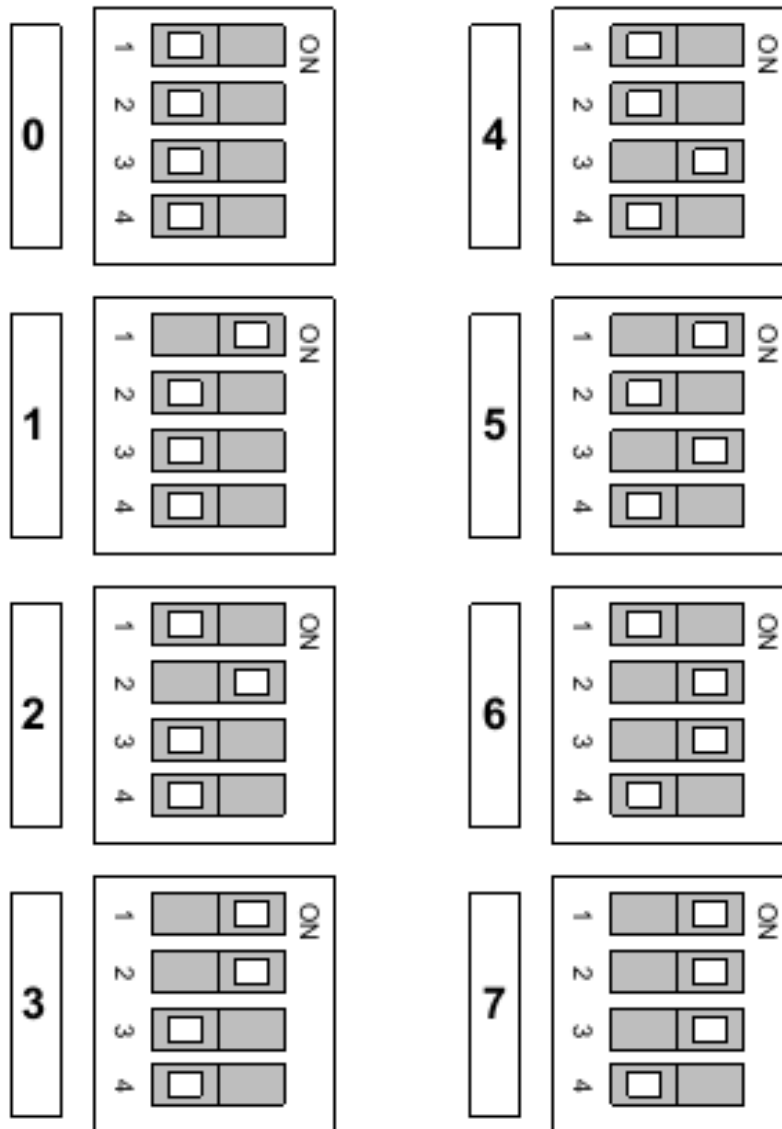

FIG. 11 NeXGen™ CCURX Mode DIP Switch Configuration

The NeXGen™ CCURX Reset Modes are customer specific, based upon NeXGen™ CCURX functional variables. The table below shows the variables and settings for the NeXGen™ CCURX when in switch position zero (0).

	Generic
Matrix Number	0
Frequency	N/A
Protocol	TS11
Trip Function 1	FN0
Close Function 1	FN1
Trip Function 2	NA
Close Function 2	NA
Voltage Override Enable	FN2
Voltage Override Disable	FN3
Tone Channel Set	1
Address Set	1
Voltage Override	Enabled
Close Safety Timer	5 minutes
Manual Close Delay	60 Seconds
Manual Trip Delay	60 Seconds
Relay Pulse Duration	18,000ms (18 sec)
Voltage Override	Enabled
Trip Voltage	125
Trip Release	122
Close Release	123
Close Voltage	120
Switching Delay	60 Seconds

FIG. 12 NeXGen™ CCURX Mode DIP Switch Position 0 Default Parameter Settings

ATTENTION

See appendix B to this manual for a complete listing of corresponding default parameter settings.

10 Jumper Local/Remote Toggle and Trip/Close Pushbutton Jumper Settings

The NeXGen™ CCURX has a series of PCB jumpers to help in configuring the NeXGen™ CCURX for your specific application, and make for easier bench top testing.

P17 – Safety Timer Interlock

P17 is a 3 pin header that requires a jumper. If the jumper shorts pin 1 and 2 of P17, the safety timer interlock is enforced. The safety timer interlock blocks the signal from the CLOSE momentary switch. The safety timer interlock duration is determined by the NeXGen™ CCURX database setting and/or Mode DIP switch position.

If P17 pin 2 and 3 are shorted, the safety timer interlock will be defeated. The CLOSE pushbutton might cause the close relay to operate immediately. The actual behavior is determined by the CCURX database. setting and/or Mode DIP switch position.



The safety timer is designed to prevent a charged capacitor from being connected to the distribution line. Industry standard capacitor banks include a bleeder resistor that allows the capacitor to discharge in 5 minutes.

W3 - Local Close Operation Function Selector

The W3 jumper installed causes close signals from the CLOSE pushbutton to be routed to the close control circuit and allows the pushbutton to control the close relay. If the safety timer interlock is active, the pushbutton will not operate the relay.

The W3 jumper removed causes the close pushbutton signal to be blocked. In this case the processor generates the local close signal. The processor generated close signal duration is defined in the NeXGen™ CCURX database setting and/or Mode DIP switch position. The safety timer rules are in force.

W4 (revision E and later only) - Local Trip Operation Function Selector

The W4 jumper installed causes trip signals from the TRIP pushbutton to be routed to the trip control circuit and allows the pushbutton to control the close relay. The safety timer interlock has no effect on the trip circuits.

The W4 jumper removed causes the pushbutton trip signal to be blocked. In this case the processor generates the local trip signal. The processor generated trip signal duration is defined in the NeXGen™ CCURX database setting and/or ModeDIP switch position. The safety timer has no effect on trip.

Other Jumper settings

W2 – Connects the “0-10 VAC1” input connectors to AN 5.

ATTENTION Jumper installation has a profound impact upon instrument functionality. Make sure that jumpers are properly installed and tested prior to deployment. (Call Telescada with questions.)

11 Autonomous Control Functionality

The NeXGen™ CCURX can execute standalone capacitor control functions in the absence of 2-way communications, or as a back up to distributed (SCADA) control via one of the following methods

- Autonomous Voltage Override Control
- Autonomous Temperature Control
- Autonomous Time of Day Control

Telescada NeXGen™ CCURX Users should refer to the Telescada NeXGen™ NGC (NeXGen™ Configurator) Users Manual to assist with programming and interrogation of Telescada NeXGen™ CCURX for autonomous control.

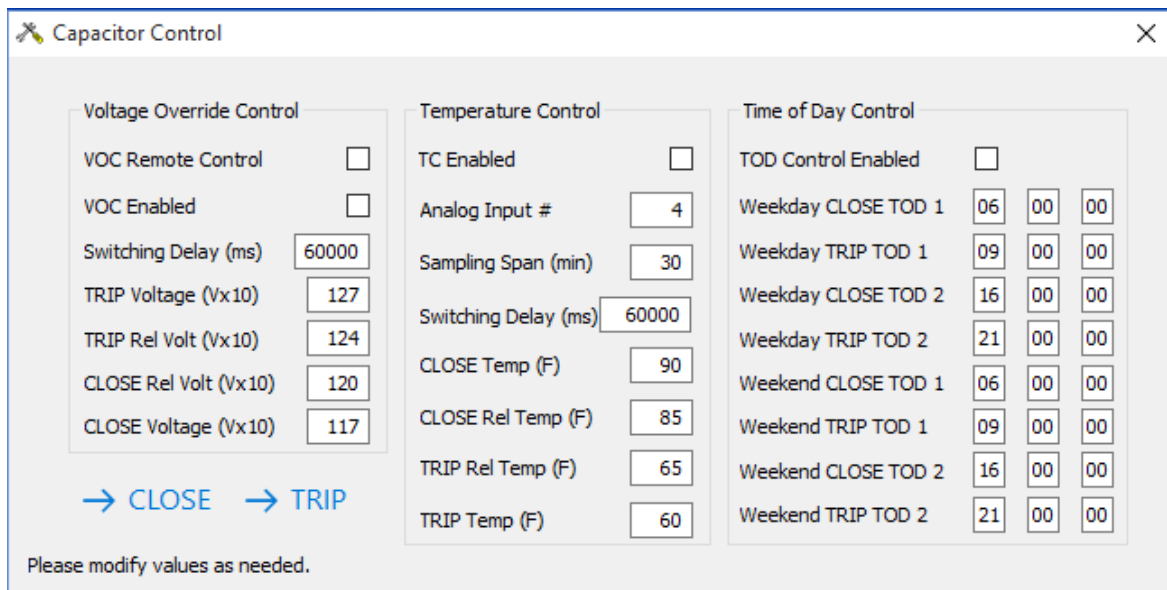

Voltage Override Control		Temperature Control		Time of Day Control	
VOC Remote Control	<input type="checkbox"/>	TC Enabled	<input type="checkbox"/>	TOD Control Enabled	<input type="checkbox"/>
VOC Enabled	<input type="checkbox"/>	Analog Input #	4	Weekday CLOSE TOD 1	06 00 00
Switching Delay (ms)	60000	Sampling Span (min)	30	Weekday TRIP TOD 1	09 00 00
TRIP Voltage (Vx10)	127	Switching Delay (ms)	60000	Weekday CLOSE TOD 2	16 00 00
TRIP Rel Volt (Vx10)	124	CLOSE Temp (F)	90	Weekday TRIP TOD 2	21 00 00
CLOSE Rel Volt (Vx10)	120	CLOSE Rel Temp (F)	85	Weekend CLOSE TOD 1	06 00 00
CLOSE Voltage (Vx10)	117	TRIP Rel Temp (F)	65	Weekend TRIP TOD 1	09 00 00
		TRIP Temp (F)	60	Weekend CLOSE TOD 2	16 00 00
				Weekend TRIP TOD 2	21 00 00

→ CLOSE → TRIP

Please modify values as needed.

FIG. 11 NeXGen™ NGC Capacitor Control Tab Screenshot

ATTENTION The NeXGen™ NGC Capacitor Control Tab provides controls for CLOSING or TRIPPING the CCURX when directly or remotely connected to NGC. Note that the safety timer is in force when the CCURX is tripped.

12 Voltage Override Functionality

The NeXGen™ CCURX has autonomous voltage override capability which allows the NeXGen™ CCURX to provide independent Capacitor Control using line voltage input. Voltage override functionality is enabled with the NeXGen™ NGC configuration utility software. The following describes the logic used by the NeXGen™ CCURX voltage override.

When Voltage Override functionality is either Enabled or Disabled A field engineer can manually operate the bank. The line voltage measurement has no influence on manual operation.

Telescada NeXGen™ CCURX Users should refer to the Telescada NeXGen™ NGC (NeXGen™ Configurator) Users Manual to assist with programming and interrogation of Telescada NeXGen™ CCURX for autonomous control.

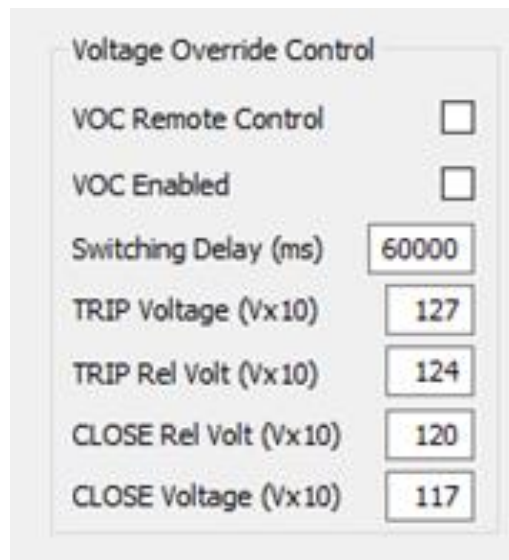

Voltage Override Control	
VOC Remote Control	<input type="checkbox"/>
VOC Enabled	<input type="checkbox"/>
Switching Delay (ms)	60000
TRIP Voltage (Vx10)	127
TRIP Rel Volt (Vx10)	124
CLOSE Rel Volt (Vx10)	120
CLOSE Voltage (Vx10)	117

FIG. 12 NeXGen™ NGC Capacitor Control Tab VOC Section Screenshot

- **VOC Remote Control** – Toggle for enabling / disabling FC – VOC Enable and FC – VOC Disable function codes.
- **VOC Enabled** – Toggle for enabling / disabling Voltage Override Control algorithm execution.
- **Switching Delay (ms)** – Number of milliseconds CCURX has to consistently measure input voltage in any region for VOC mode to switch accordingly.
- **TRIP Voltage (V)** – Voltage which, when crossed from below, and consistently measured for longer than Switching Delay ms, makes CCURX issue the TRIP command, and enter TRIPPED mode. In this mode remotely generated relay operation commands are not executed.

- **TRIP Release Voltage (V)** – Voltage which, when crossed from above, and consistently measured in TRIP mode for longer than Switching Delay ms, makes CCURX enter REMOTE mode. In this mode remotely generated relay operation commands are executed.
- **CLOSE Release Voltage (V)** – Voltage which, when crossed from below, and consistently measured in CLOSED mode for longer than Switching Delay ms, makes CCURX enter REMOTE mode. In this mode remotely generated relay operation commands are executed.
- **CLOSE Voltage (V)** – Voltage which, when crossed from above, and consistently measured for longer than Switching Delay ms, makes CCURX issue the CLOSE command, and enter CLOSED mode. In this mode remotely generated relay operation commands are not executed

13 Autonomous Temperature Control

The NeXGen™ CCURX has autonomous Temperature Control capability which allows the NeXGen™ CCURX to provide independent Capacitor Control using ambient temperature input. Temperature Control functionality is enabled with the NeXGen™ NGC configuration utility software. The following describes the settings and logic used by the NeXGen™ CCURX for autonomous Temperature Control.

When Temperature Control functionality is either Enabled or Disabled A field engineer can manually operate the bank. Temperature measurement has no influence on manual operation.

Telescada NeXGen™ CCURX Users should refer to the Telescada NeXGen™ NGC (NeXGen™ Configurator) Users Manual to assist with programming and interrogation of Telescada NeXGen™ CCURX for autonomous control.

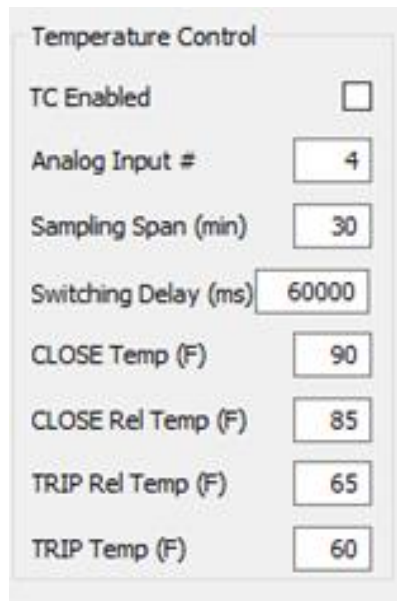

Temperature Control	
TC Enabled	<input type="checkbox"/>
Analog Input #	4
Sampling Span (min)	30
Switching Delay (ms)	60000
CLOSE Temp (F)	90
CLOSE Rel Temp (F)	85
TRIP Rel Temp (F)	65
TRIP Temp (F)	60

FIG. 13 NeXGen™ NGC Capacitor Control Tab TC Section Screenshot

- **TC Enabled** – Toggle for enabling / disabling Temperature Control algorithm execution.
- **Analog Input #** - Number of analog input which hosts temperature sensor.
- **Sampling Span** – Number of minutes over which temperature is sampled. 128 temperature readings are taken over this time period, average temperature computed from these samples is used control parameter for temperature control algorithm.
- **Switching Delay (ms)** – Number of milliseconds CCURX has to consistently measure temperature in any region for TC mode to switch accordingly.
- **CLOSE Temp (F)** – Temperature, in deg. F, which, when crossed from below, and consistently measured for longer than Switching Delay ms, makes CCURX issue the CLOSE command, and enter CLOSED mode. In this mode remotely generated relay operation commands are not executed.
- **CLOSE Release Temp (F)** – Temperature which, when crossed from above, and consistently measured in CLOSED mode for longer than Switching Delay ms, makes CCURX enter REMOTE mode. In this mode remotely generated relay operation commands are executed.
- **TRIP Release Temperature (F)** – Temperature which, when crossed from below, and consistently measured in TRIPPED mode for longer than Switching Delay ms, makes CCURX enter REMOTE mode. In this mode remotely generated relay operation commands are executed.
- **TRIP Temperature (F)** – Temperature which, when crossed from above, and consistently measured for longer than Switching Delay ms, makes CCURX issue the TRIP command, and enter TRIPPED mode. In this mode remotely generated relay operation commands are not executed.

14 Autonomous Time of Day Control

The NeXGen™ CCURX has autonomous Time of Day Control capability which allows the NeXGen™ CCURX to provide independent Capacitor Control using Time of Day input. Time of Day Control functionality is enabled with the NeXGen™ NGC configuration utility software. The following describes the settings and logic used by the NeXGen™ CCURX for autonomous Time of Day Control.

When Time of Day Control functionality is either Enabled or Disabled A field engineer can manually operate the bank. Time of Day has no influence on manual operation.

Telescada NeXGen™ CCURX Users should refer to the Telescada NeXGen™ NGC (NeXGen™ Configurator) Users Manual to assist with programming and interrogation of Telescada NeXGen™ CCURX for autonomous control.

Time of Day Control

TOD Control Enabled

Weekday CLOSE TOD 1 06 00 00

Weekday TRIP TOD 1 09 00 00

Weekday CLOSE TOD 2 16 00 00

Weekday TRIP TOD 2 21 00 00

Weekend CLOSE TOD 1 06 00 00

Weekend TRIP TOD 1 09 00 00

Weekend CLOSE TOD 2 16 00 00

Weekend TRIP TOD 2 21 00 00

FIG. 14 NeXGen™ NGC Capacitor Control Tab TOD Section Screenshot

- **TOD Enabled** – Toggle for enabling / disabling Time of Day Control algorithm execution. Before enabling this algorithm user must make certain NeXGen unit real time clock has been properly set.
- **Weekday CLOSE TOD 1** – First weekday (Mon – Fri) time of day (military time) when capacitor bank is set on-line (CLOSE relay is pulsed).
- **Weekday TRIP TOD 1** – First weekday (Mon – Fri) time of day (military time) when capacitor bank is set off-line (TRIP relay is pulsed).
- **Weekday CLOSE TOD 2** – Second weekday (Mon – Fri) time of day (military time) when capacitor bank is set on-line (CLOSE relay is pulsed).
- **Weekday TRIP TOD 2** – Second weekday (Mon – Fri) time of day (military time) when capacitor bank is set off-line (TRIP relay is pulsed).
- **Weekend CLOSE TOD 1** – First weekend (Sat, Sun) time of day (military time) when capacitor bank is set on-line (CLOSE relay is pulsed).
- **Weekend TRIP TOD 1** – First weekend (Sat, Sun) time of day (military time) when capacitor bank is set off-line (TRIP relay is pulsed).
- **Weekend CLOSE TOD 2** – Second weekend (Sat, Sun) time of day (military time) when capacitor bank is set on-line (CLOSE relay is pulsed).
- **Weekend TRIP TOD 2** – Second weekend (Sat, Sun) time of day (military time) when capacitor bank is set off-line (TRIP relay is pulsed).

15 DNP Device Profile

15.1 Device Profile

DNP V3.0 DEVICE PROFILE DOCUMENT	
Vendor Name:	Telescada
Device Name:	NeXGen™ 3700 Instrument Platform
Device Function:	Slave
Maximum Data Link Frame Size (octets):	Transmitted: 292 Received 292
Maximum Data Link Re-Tries:	Configurable, range 0 to 5, via NGC
Maximum Application Layer Fragment Size (octets):	Transmitted: 2048 Received: 2048
Maximum Application Layer Re-Tries:	Configurable, range 0 to 5, via NGC
Requires Data Link Confirmation:	Configurable, via NGC
Requires Application Layer Confirmation:	Configurable, via NGC
Timeouts While Waiting For:	Data Link Confirm: Configurable via NGC Complete Appl. Fragment: Configurable via NGC Application Confirm: Configurable via NGC Complete Appl. Response: Configurable via NGC
Executes Control Operations:	WRITE Binary Outputs: Never SELECT/OPERATE: Always DIRECT OPERATE: Always DIRECT OPERATE - NO ACK: Configurable via NGC Count > 1: Never Pulse On: Always Pulse Off: Always Latch On: Always Latch Off: Always Queue: Never Clear Queue: Never
Reports Binary Input Change Events When No Specific Variation Requested:	Configurable via NGC, Never or Time-tagged

Reports Time-tagged Binary Input Change Events When No Specific Variation Requested: Configurable via NGC, Never or Change With Time
Sends Unsolicited Responses: Configurable via NGC, See Explanation Below
Sends Static Data in Unsolicited Responses: Never

15.2 Unsolicited Responses

The unit sends unsolicited responses only when configured to do so, using NGC. Only events (no static data) are reported in this manner.

Event generation can be enabled or disabled.

Event reporting can be enabled or disabled. Events can be retrieved via active polling by the master, or in unsolicited fashion. In the latter case the unit can be configured to let the master know events are available (after which the master must poll for events), or it can be configured to send all available event data.

In case of analog inputs, for an event to be generated, analog input value must cross configurable high or low threshold. Configurable chatter filter and event class are available.

In case of counters, for an event to be generated, counter value change since last report must cross configurable threshold. Configurable chatter filter and event class are available.

In case of status (binary) inputs, for an event to be generated, binary input value must change. Configurable chatter filter and event class are available.

In case of control (binary) outputs, for an event to be generated, binary output value must be changed by someone other than the slave. Configurable chatter filter and event class are available.

15.3 Implementation Table

Request columns identify all requests parsed by the device. Response columns identify all responses sent by the device.

Obj	Var	Description * = Default Responses ** = Event Unsolicited Responses	Req. Func. Codes	Req. Qual. Codes (hex)	Resp. Func. Codes	Resp. Qual. Codes (hex)
01	01	SINGLE-BIT BINARY INPUT	1	All	129	27
01	02	BINARY INPUT WITH STATUS*	1	All	129	27
02	01	BINARY INPUT CHANGE WITHOUT TIME	1	All	129	27
02	02	BINARY INPUT CHANGE WITH TIME* **	1	All	129, 130	27
10	01	BINARY OUTPUT	3,4,5, 6	All	129	27
10	02	BINARY OUTPUT STATUS**	1	All	129, 130	27
12	01	CONTROL RELAY OUTPUT BLOCK	2	All	129	27
20	01	32-BIT BINARY COUNTER*	1	All	129	27
20	02	16-BIT BINARY COUNTER	1	All	129	27
21	05	32-BIT FROZEN COUNTER WITH TIME OF FREEZE**	1	All	129, 130	27
30	01	32-BIT ANALOG INPUT*	1	All	129	27
30	02	16-BIT ANALOG INPUT	1	All	129	27
30	03	32-BIT ANALOG INPUT WITHOUT FLAG	1	All	129	27
30	04	16-BIT ANALOG INPUT WITHOUT FLAG	1	All	129	27
31	03	32-BIT FROZEN ANALOG INPUT WITH TIME OF FREEZE**	1	All	129, 130	27
50	01	TIME AND DATE	2	All	129	
50	02	TIME DELAY FINE	17	All	129	
60	01	CLASS 0 DATA	1	All		27
60	02	CLASS 1 DATA	1	All		27
60	03	CLASS 2 DATA	1	All		27
60	04	CLASS 3 DATA	1	All		27
80	01	INTERNAL INDICATIONS	1, 2	All	129	
83	01	PRIVATE REGISTRATION OBJECT – See Below.	1, 2	All	129	27

15.4 Private Registration Object

Private registration object is used to implement device specific functionality. In all cases:

- The four 'Vendor' bytes are (hex) 42 54 45 00.
- The six byte (48 bit) time is in standard DNP time format.

The table below shows this object Private Registration Numbers (PRN), and associated functionality.

PRN	F	DATA
0	2	Set data recording period, in ms (4 bytes)
1	1	Download analog point data 'since' time (6 bytes), point index (4 bytes), max readings (4 bytes)
2	1	Download pulse counter data 'since' time (6 bytes), point index (4 bytes), max readings (4 bytes)
3	1	Download status point data 'since' time (6 bytes), point index (4 bytes), max readings (4 bytes)
4	1	Reserved.
5	2	Analog point data recording Enable == 1, Disable == 0 (1 byte), point index (4 bytes)
6	2	Pulse counter data recording Enable == 1, Disable == 0 (1 byte), point index (4 bytes)
7	2	Status point data recording Enable == 1, Disable == 0 (1 byte), point index (4 bytes)
8	2	Reserved.
9	2	Reserved.
10	1,2	Reserved

In above Table:

- Column Header 'F' is Application Layer function: 1 = Read, 2 = Write.
- Response to data downloads consists of standard DNP time stamped objects.

Control Point Operation

Control point operation is implemented via DNP object Group 12, Variation 01. The software follows minimum implementation outlined in *DNP Technical Bulletin 9701-002*. The following combinations are implemented (object fields, as expected by CCDC for the various functions):

Control	Ctl. Code	Count	On Time	Off Time
Latching OFF (Conditional – 2WLM)	0x4	0	0	0
Latching ON	0x3	Ignored	0	0
Latching OFF (Unconditional)	0x4	1	0	0
Latching ON	0x3	Ignored	0	0
Pulse / Timed OFF	0x81	Ignored	n > 0 (ms)	0
Pulse ON	0x41	Ignored	n > 0 (ms)	0

The following functions are supported in conjunction with above object: *select before operate*, *operate*, and *direct operate*. Success or failure of operation is returned via returned object Status field. Possible values:

- 0 Request accepted, initiated, or queued.
- 1 Request not accepted as the operate message was received after the arm timer timed out. The arm timer was started when the select operation for the same point was received.
- 2 No previous matching select message (i.e. an operate message was sent to activate a control point that was not previously armed with the select message).
- 3 Request not accepted as there were formatting errors in the *control* request (*select*, *operate*, or *direct operate*).
- 4 Control operation not supported for this point.
- 5 Request not accepted, as the control queue is full or the point is already active.
- 6 Request not accepted because of control hardware problems.

The actual relay operations (processor board → I/O board) are done via the SPI.

DNP 3.0 Slave (DNPS)

DNP slaves communicate with assigned external master stations. Two independent, asynchronous slaves are available, one on each port. When both slaves are mapped to the same communications port, secondary slave is disabled. Each slave

- Responds to polls for data from the master station,
- Reports data events and software error events to the master station (unsolicited reports)
- Executes commands issued by the master station, including
 - Clock synchronization with the master station
 - Operation of relays on attached I/O board
 - Database updates (RTU configuration editing)
 - Data recording management and data downloads

- Stores and forwards messages to the local DNP master running concurrently with the slave (in support of message routing).

The following DNP objects are supported:

Group	Variation	Format
01	1	SINGLE-BIT BINARY INPUT
01	2	BINARY INPUT WITH STATUS
02	1	BINARY INPUT CHANGE WITHOUT TIME
02	2	BINARY INPUT CHANGE WITH TIME
10	1	BINARY OUTPUT
10	2	BINARY OUTPUT STATUS
12	1	CONTROL RELAY OUTPUT BLOCK
20	1	32-BIT BINARY COUNTER
20	2	16-BIT BINARY COUNTER
21	5	32-BIT FROZEN COUNTER WITH TIME OF FREEZE
30	1	32-BIT ANALOG INPUT
30	2	16-BIT ANALOG INPUT
30	3	32-BIT ANALOG INPUT WITHOUT FLAG
30	4	16-BIT ANALOG INPUT WITHOUT FLAG
31	3	32-BIT FROZEN ANALOG INPUT WITH TIME
50	1	TIME AND DATE
52	2	TIME DELAY FINE
60	1	CLASS 0 DATA
60	2	CLASS 1 DATA
60	3	CLASS 2 DATA
60	4	CLASS 3 DATA
80	1	INTERNAL INDICATIONS
83	1	PRIVATE REGISTRATION OBJECT

Data Recording Control

Data recording can be controlled via DNP object G83V01 write operations. The following table lists supported PRN values and their corresponding functionality.

PRN	DATA
0	Set data recording period, in milliseconds (4 bytes), 0 == Off
5	Analog point data recording Enable == 1, Disable == 0 (1 byte), point index (4 bytes)
6	Counter data recording Enable == 1, Disable == 0 (1 byte), point index (4 bytes)
7	Status point data recording Enable == 1, Disable == 0 (1 byte), point index (4 bytes)

DNP 3.0 Master (DNPM)

DNP master communicates with external DNP slave stations. The master

- Forwards messages received from the local, concurrently running DNP slave to remote slave stations (store and forward routing)
- Stores replies from external slaves, and forwards them to the local, concurrently running DNP slave (store and forward routing)
- Stores unsolicited reports from external slaves, and forwards them to the local, concurrently running DNP slave (store and forward routing)

Master functions are not available when two slaves are being used. For supported DNP objects please see the table in the *DNP 3.0 Slave (DNPS)* section.

Modbus Slaves

Modbus slaves communicate with assigned external master stations. Two independent, asynchronous slaves are available, one on each port. When both slaves are mapped to the same communications port, secondary slave is disabled.

Base Register Map

Complexity of NeXGen platform prohibits existence of one simple register map. The map changes as programming of the instrument changes. For this reason a 'base' register map exists, in a sense a map of maps (metadata), which publishes numeric values for all other register maps for a given instrument configuration that is in effect at the time when the base register map is downloaded.

Register Number	Symbol	Description
0	AN	Base register # for analog points (including PowerPoll).
1	NAN	Number of analog point registers (including PowerPoll), including point addresses
2	A0	Base register # for analog points Min. values
3	NA0	Number of analog point Min. value registers, including point addresses
4	A1	Base register # for analog points Max. values
5	NA1	Number of analog point Max. value registers, including point addresses
6	A2	Base register # for analog points Ave. values
7	NA2	Number of analog point Ave. value registers, including point addresses

8	CN	Base register # for counters
9	NCN	Number of counter registers, including point addresses
10	ST	Base register # for status points
11	NST	Number of status point registers, including point addresses
12	CT	Base register # for control points
13	NCT	Number of control point registers, including point addresses
14	DC	Base register # for data recording control
15	NDC	Number of registers for data recording control
16	DL	Base register # for data recording downloads
17	NDL	Number of registers for data recording downloads
18	NPT	Base register number for programming of the unit - unit time
19	NNPT	Number of registers used for transferring time from master to unit
20	P0	Base register number for programming of the unit - unit configuration
21	NP0	Number of registers used for transferring unit configuration
22	P1	Base register number for programming of the unit - I/O point attributes
23	NP1	Number of registers used for transferring unit configuration - I/O point attributes
24	P2	Base register number for programming of the unit - DNP configuration
25	NP2	Number of registers used for transferring unit configuration - DNP configuration
26	P3	Base register number for programming of the unit - Modbus configuration
27	NP3	Number of registers used for transferring unit configuration - Modbus configuration

Current Data Register Map

To poll for current data, a master uses values obtained from the base table. Let 'R' represent a general register symbol (AN, AP, CN, etc.), and let 'NR' represent the number of those registers obtained from the same table. Standard Modbus (16 bit registers) Latest Data map looks like this:

Byte No.	Reg. No.	Item
0	R	Point Index – MSB
1	R	Point Index
2	R + 1	Point Index
3	R + 1	Point Index – LSB

4	R + 2	Point Value – MSB
5	R + 2	Point Value
6	R + 3	Point Value
7	R + 3	Point Value – LSB
8	R + 4	Point Index – MSB
Etc.		

Enron Modbus (32 bit registers) Latest Data map looks like this:

Byte No.	Reg. No.	Item
0	R	Point Index – MSB
1	R	Point Index
2	R	Point Index
3	R	Point Index – LSB
4	R + 1	Point Value – MSB
5	R + 1	Point Value
6	R + 1	Point Value
7	R + 1	Point Value – LSB
8	R + 2	Point Index – MSB
Etc.		

Example: Suppose an instrument, running standard Modbus (registers are 16 bits wide), has four counters with addresses 0, 1, 2, 3, but only three of them are enabled – 0, 1, and 3 (pulse counter #2 is disabled). Suppose one wants to poll for values of the three enabled counters ($R = CN$), and suppose that polling base register map returns $R = CN = 1000$, and $NR = NCN = 12$. In this case, the counter portion of Latest Data table looks like this:

Byte No.	Reg. No.	Item
0	1000	0
1	1000	0
2	1001	0
3	1001	0
4	1002	Point Value – MSB
5	1002	Point Value
6	1003	Point Value
7	1003	Point Value – LSB
8	1004	0
9	1004	0
10	1005	0
11	1005	1
12	1006	Point Value – MSB

13	1006	Point Value
14	1007	Point Value
15	1007	Point Value – LSB
16	1008	0
17	1008	0
18	1009	0
19	1009	3
20	1010	Point Value – MSB
21	1010	Point Value
22	1011	Point Value
23	1011	Point Value – LSB

In above case, function 03 poll needs to request 12 registers, starting with register address 1000.

In general, Modbus function 03 poll needs to request base register address R, and number of registers 4*NR (2*NR for Enron Modbus). If more registers are requested, only number of registers available is returned. If fewer registers are requested, only requested number of registers is returned.

In order to be able to retrieve all current data with a single poll, the following equations can always be assumed to be true:

$$\begin{aligned}
 A0 &= AN + NAN \\
 A1 &= A0 + NA0 \\
 A2 &= A1 + NA1 \\
 CN &= A2 + NA2 \\
 ST &= CN + NCN \\
 CT &= ST + NST
 \end{aligned}$$

This means that data mapping listed in base register map registers 0 – 13 is made contiguous. So to poll for all current data, Modbus 03 function call with base register number AN, and number of registers 4*(NAN + NCN + NST + NCT + NA0 + NA1 + NA2) needs to be made (once again, above multiplier is 2 instead of 4 in case of Enron Modbus).

One should be aware of Modbus protocol limitations though. Response length limit is governed by the 'Number of Bytes' field which is 8 bits wide. Maximum number of data bytes in a response is, therefore, limited to 256. For standard Modbus flavors (16 bit registers) this means at most 128 registers can be returned at any one time, while Enron flavors of Modbus (32 bit registers) can only return 64 registers at a time.

Data Recording Control

Data recording can be controlled by writing to register DC, and adjacent registers. Number of registers is not to exceed NDC. The following tables show register values and interpretation:

Register#	Data
DC	PRN (See table below)
DC + 1	Data, as needed per PRN (above) and table (below)
DC + 2	Data, as needed per PRN (above) and table (below)
DC + 3	Data, as needed per PRN (above) and table (below)

PRN	DATA
0	Set data recording period, in milliseconds (4 bytes, one register for Enron format, two registers otherwise), 0 == Off
5	Analog point data recording Enable == 1, Disable == 0 (1 byte, one register), point index (4 bytes, one register for Enron format, two registers otherwise).
6	Counter data recording Enable == 1, Disable == 0 (1 byte, one register), point index (4 bytes, one register for Enron format, two registers otherwise).
7	Status point data recording Enable == 1, Disable == 0 (1 byte), point index (4 bytes, one register for Enron format, two registers otherwise).

Data Recording Control Example

 Message To NeXGen - Turn on Data Recording, period = 1 minute
 01 - NeXGen Address
 10 - Function 16
 05 - Start Address Hi
 00 - Start Address Lo
 00 - No. of Registers Hi
 03 - No. of Registers Lo
 06 - Byte Count
 00 - PRN Hi
 00 - PRN - Lo
 00 - Data Recording Milliseconds
 00 - Data Recording Milliseconds
 EA - Data Recording Milliseconds
 60 - Data Recording Milliseconds
 B8 - CRC
 04 - CRC

Response From NeXGen

01 - NeXGen Address
10 - Function 16
05 - Start Address Hi
00 - Start Address Lo
00 - No. of Registers Hi
03 - No. of Registers Lo
80 - CRC
C4 - CRC

Message To NeXGen - Start data recording on one analog point, point address = 1

01 - NeXGen Address
10 - Function 16
05 - Start Address Hi
00 - Start Address Lo
00 - No. of Registers Hi
04 - No. of Registers Lo
08 - Byte Count
00 - PRN Hi
05 - PRN - Lo
00 - Data Recording Enable / Disable Hi
01 - Data Recording Enable / Disable Lo
00 - Point Address
00 - Point Address
00 - Point Address
01 - Point Address
13 - CRC
7F - CRC

Response From NeXGen

01 - GCU Address
10 - Function 16
05 - Start Address Hi
00 - Start Address Lo
00 - No. of Registers Hi
04 - No. of Registers Lo
C1 - CRC
06 - CRC

Data Downloads

Data downloads are done by writing to register DL, and adjacent registers. Number of registers is not to exceed NDL. The following table shows register values and interpretation:

Each download of data recorded by the unit is done in two steps:

First, download request parameters are uploaded (written to unit registers) per tables below.

Register#	Data
DL	PRN, 1 = analog point data, 2 = counter data, 3 = status point data (4 bytes, one register for Enron format, two registers otherwise)
DL + ...	Data, as needed per PRN (above) and table (below)

# of bytes	DATA
6	Oldest time stamp of data to download, 48 bit AT format.
4	I/O point index (address) (One register for Enron format, two registers otherwise)
4	Max. number of readings to download (One register for Enron format, two registers otherwise)

Second, data is downloaded per above request by requesting maximum number of readings, starting with register number DL. The unit returns maximum number of readings worth of data or less, depending on whether enough data is available. For regular Modbus flavors (16 bit registers), downloaded data is returned as shown below:

Register#	Data
DL	Bytes 5 and 4 of AT format time stamp.
DL + 1	Bytes 3 and 2 of AT format time stamp.
DL + 2	Bytes 1 and 0 of AT format time stamp.
DL + 3	Bytes 3 and 2 of I/O point value
DL + 4	Bytes 1 and 0 of I/O point value

For Enron Modbus flavors (32 bit registers), downloaded data is returned as shown below:

Register#	Data
DL	Bytes 5 and 4 of AT format time stamp.
DL + 1	Bytes 3, 2, 1, and 0 of AT format time stamp.
DL + 2	I/O point value

Data Downloads Example

Below is example of data download conversation with NeXGen, in Modbus. Please note, all internal NeXGen time stamps are UTC time, so time keeping within units is invariant with respect to time zones:

 Message To NeXGen - Request Data Newer than 12/4/2010 11:10:00 Eastern Time, No More than 10 values Max.:

01 - NeXGen Address
 10 - Function 16
 06 - Start Address Hi
 00 - Start Address Lo
 00 - No. of Registers Hi
 08 - No. of Registers Lo
 10 - Byte Count
 00 - PRN Hi
 01 - PRN Lo
 01 - AT Time - MSB
 2C - AT Time
 B2 - AT Time
 DD - AT Time
 A9 - AT Time
 20 - AT Time - LSB
 00 - Point Address
 00 - Point Address
 00 - Point Address
 01 - Point Address
 00 - Max Readings
 00 - Max Readings
 00 - Max Readings
 0A - Max Readings
 0A - CRC
 FB - CRC

 Response From NeXGen - Standard Modbus Function Confirmation 16 Response

01 - NeXGen Address
 10 - Function 16
 06 - Start Address Hi
 00 - Start Address Lo
 00 - No. of Registers Hi

08 - No. of Registers Lo
C1 - CRC
47 - CRC

Message To NeXGen - Download Data Specified in Above Request

01 - NeXGen Address
03 - Function 3
06 - Start Address Hi
00 - Start Address Lo
00 - No. of Registers Hi
80 - No. of Registers Lo
44 - CRC
E2 - CRC

Message From NeXGen - Requested Data

01 - NeXGen Address
03 - Function 3
6E - Byte Count
01 - AT Time Stamp
2C - AT Time Stamp
B2 - AT Time Stamp
DE - AT Time Stamp
93 - AT Time Stamp
A8 - AT Time Stamp
00 - Point Value
00 - Point Value
00 - Point Value
00 - Point Value
01 - AT Time Stamp
2C - AT Time Stamp
B2 - AT Time Stamp
DF - AT Time Stamp
7E - AT Time Stamp
09 - AT Time Stamp
00 - Point Value
00 - Point Value
00 - Point Value
00 - Point Value
01 - AT Time Stamp
2C - AT Time Stamp
B2 - AT Time Stamp
E0 - AT Time Stamp
68 - AT Time Stamp

64 - AT Time Stamp
00 - Point Value
00 - Point Value
00 - Point Value
00 - Point Value
01 - AT Time Stamp
2C - AT Time Stamp
B2 - AT Time Stamp
E1 - AT Time Stamp
52 - AT Time Stamp
D6 - AT Time Stamp
00 - Point Value
00 - Point Value
00 - Point Value
00 - Point Value
01 - AT Time Stamp
2C - AT Time Stamp
B2 - AT Time Stamp
E2 - AT Time Stamp
3D - AT Time Stamp
30 - AT Time Stamp
00 - Point Value
00 - Point Value
00 - Point Value
00 - Point Value
01 - AT Time Stamp
2C - AT Time Stamp
B2 - AT Time Stamp
E3 - AT Time Stamp
27 - AT Time Stamp
82 - AT Time Stamp
00 - Point Value
00 - Point Value
00 - Point Value
00 - Point Value
01 - AT Time Stamp
2C - AT Time Stamp
B2 - AT Time Stamp
E4 - AT Time Stamp
11 - AT Time Stamp
E5 - AT Time Stamp
00 - Point Value
00 - Point Value
00 - Point Value
00 - Point Value
01 - AT Time Stamp

2C - AT Time Stamp
B2 - AT Time Stamp
E4 - AT Time Stamp
FC - AT Time Stamp
47 - AT Time Stamp
00 - Point Value
00 - Point Value
00 - Point Value
00 - Point Value
01 - AT Time Stamp
2C - AT Time Stamp
B2 - AT Time Stamp
E5 - AT Time Stamp
E6 - AT Time Stamp
AA - AT Time Stamp
00 - Point Value
00 - Point Value
00 - Point Value
00 - Point Value
01 - AT Time Stamp
2C - AT Time Stamp
B2 - AT Time Stamp
E6 - AT Time Stamp
D1 - AT Time Stamp
0C - AT Time Stamp
00 - Point Value
00 - Point Value
00 - Point Value
00 - Point Value
01 - AT Time Stamp
2C - AT Time Stamp
B2 - AT Time Stamp
E7 - AT Time Stamp
BB - AT Time Stamp
6F - AT Time Stamp
00 - Point Value
00 - Point Value
00 - Point Value
00 - Point Value
40 - CRC
47 - CRC

Control Point Operation

Control point operation via Modbus can be done in one of two ways:

1. Using a single function 16 message, as shown in the table below (example in Modbus RTU flavor):

Byte (hex value)	Interpretation
11	Unit address (in this example address = 17)
10	Modbus Function (16)
CT – Hi	Hi byte of value of CT (from base register map)
CT – Lo	Lo byte of value of CT (from base register map)
00	Hi byte for Number of registers
02	Lo byte for number of registers
04	Byte count (this value = 8 for Enron flavors of Modbus)
00	Hi byte of control point address (in this example address = 2)
02	Lo byte of control point address (in this example address = 2)
TT	Hi byte – point state parameters (see below)
OP	Lo byte – point state parameters (see below)
CRC – Hi	Hi byte – CRC
CRC – Lo	Lo byte – CRC

One can choose the following TT and OP values from the table below:

OP	Meaning	Supported TT Values
00	Latched Operation	TT > 0 for ON, TT = 0 for OFF
01	Timed Operation	TT > 0 (in minutes) for OFF, TT = 0 for ON
02	Timed Operation	TT > 0 (in minutes) for ON, TT = 0 for OFF
03	Momentary Op.	TT > 0 (in milliseconds) for ON, TT = 0 for OFF
04	Momentary Op.	TT > 0 (in milliseconds) for OFF, TT = 0 for ON

2. Using two messages. First, Modbus function 6 message writes time (pulse duration) to a register as shown below (example in Modbus RTU flavor):

Byte (hex value)	Interpretation
11	Unit address (in this example address = 17)
06	Modbus Function (6)
CT – Hi	Hi byte of value of CT (from base register map)
CT – Lo	Lo byte of value of CT (from base register map)
00	Hi byte of duration (in this example 15 milliseconds)
0F	Lo byte of duration (in this example 15 milliseconds)
CRC – Hi	Hi byte – CRC
CRC – Lo	Lo byte – CRC

Second, Modbus function 5 message sets a 'coil' to activate the command.

Byte (hex value)	Interpretation
11	Unit address (in this example address = 17)
05	Modbus Function (5)
00	Hi byte of control point address (in this example address = 2)
02	Lo byte of control point address (in this example address = 2)
OP	Hi byte – point state parameters (see below)
00	Lo byte – point state parameters (always 00)
CRC – Hi	Hi byte – CRC
CRC – Lo	Lo byte – CRC

Above, OP = FF for ON, 00 for OFF.

Data Sampling

CCDC scans all analog, counter, and status inputs, as well as control outputs on attached I/O board, and records the readings once every 100 milliseconds (default). This period is parameterized and can be changed. At the time of each scan, all computed values (Min., Max., and Ave.) are also updated.

Data Events

Sampled data is analyzed; events are generated if so configured. Globally, event generation must be enabled. On a point by point basis, an I/O point generates an event if the following conditions are satisfied:

- The point is enabled,
- The point's event generation is enabled,
- The point's chatter filter is not active (see below),
- The point class is 1, 2, or 3 (but not 0),
- The point event triggering condition has occurred.

Event triggering conditions vary by point type:

- Analog points must cross value region (high, OK, low) thresholds
- Counters must change by more than pre-configured amount
- Status points must change state
- Control points must change state

I/O point chatter filter is active when point inactivity period is defined, and previous event occurred less than that amount of time ago. Chatter filtering can be turned off on a point by point basis.

Events are reported quiescently (if so configured) or by polling. Unsolicited reports can be of two types, depending on configuration:

- Notification Only – report notifies the master that there is event data. It is up to the master to poll for event data when convenient.
- All Data – all event data is reported to the master station.

Default DNP objects used by CCDC to report event data quiescently are as follows:

- Analog Points – Group 31, Variation 03
- Counters – Group 21, Variation 05
- Status Points – Group 02, Variation 02
- Control Points – Group 10, Variation 02

Except for control points, above objects are used because they contain event date and time information.

Data Recording

Data recording can be configured by NTMC, or NGC (RTU database upload). Every I/O point can be individually configured to record data. The following conditions need to be satisfied for I/O point data to be recorded:

- Data recording must be enabled globally
- Data recording interval must be defined (one interval for all I/O points)
- I/O point must be enabled
- Data recording must be enabled locally (I/O Point)

In addition,

- Data recording cannot be enabled until TSB is set to TRUE. This is to make sure that RTC has been set. – see time-keeping above.
- Data recording parameters (record schema, sampling frequency, etc) are defined in station configuration record.
- To minimize the number of writes onto serial flash disk, every sampling period all readings are stored as one record. Record structure is indicated

below.

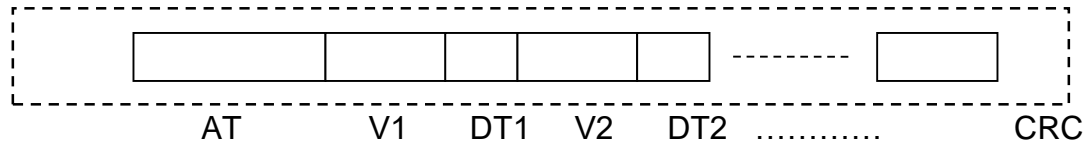

Above:

- AT = Absolute Time when measurement of all quantities in the record began.
- V1 = Value of the first measured item (number of bytes depends on item)
- DT1 = Number of milliseconds after AT when V1 was measured (1 byte)
- V2 = Value of the second measured item (number of bytes depends on item)
- DT2 = Number of milliseconds after AT when V2 was measured (1 byte)
- CRC = Checksum of the record

Each record lists values in the following order:

- Analog values (enabled I/O points only, if any) (4 bytes each)
- Counters (enabled I/O points only, if any) (4 bytes each),
- Status values (enabled I/O points only, if any) (1 byte each)
- Control point Boolean values (enabled I/O points only, if any) (TRUE / FALSE) (1 byte each).

Data Recording Startup Sequence

At startup, once data recording has been initialized and enabled, CCDC goes through the following steps to start data recording:

- Serialized record structure is constructed from data recording record schema in station's configuration database.
- The latest (newest) record in data recording database is tested for integrity and verified to be the latest record on file by using indexes stored in battery backed up RAM (BBRAM). If this fails (failure may occur after firmware update, battery replacement, etc), serial flash disk pages are scanned to find the last (newest) record in data recording database.
- Wait until after TSB is set to TRUE.
- Schedule the next data recording

Error Events

CCDC reports errors via DNP event mechanism when `CCDC_ERROR_EVENT_PRINTOUTS` is not defined. When an error occurs, a pair

of 32 bit unsigned integer values is generated. Both values are reported as DNP class 1 events associated with a pair of analog points with respective addresses 0xFFE (4094) and 0xFFF (4095). The first value register (reported as analog value at address 0xFFE) is partitioned as follows:

- Event Identifier (bits – 0 – 7, bit 0 = lsb)
- Source file id (bits 8 – 15)
- Source file line number (bits 16 – 29)
- Event log entry value type (bits 30 – 31)

The second value register (reported as analog value at address 0xFFF) is filled with entry value, if any. The tables below list the various identifiers in the first register.

Error Event Identifiers – System Resources

0	System restart
1	Memory allocation failure
2	Serial port open failure
3	Failed to send data via RS232 port
4	Failed to initialize serial flash disk
5	Serial flash disk page read failed
6	Serial flash disk RAM read failed
7	Serial flash disk RAM write failed
8	Serial flash disk page write failed
9	System restart requested

Error Event Identifiers – System Miscellaneous

50	Copy from root to xtended memory (root2xmem) failure
51	Copy from xtended memory to root(xmem2root) failure
52	Destination buffer too short
53	General assertion failure
54	Index out of bounds condition has occurred
55	Sorting of an array failed
56	This station database version mismatch
57	Serial Flash Disk page too short
58	This station database CRC mismatch
59	Failed to set this station time
60	Failed to sample data
61	Data recording record larger than SFD page
62	Data recorder failed to locate oldest record on SFD
63	Failed to record data
64	Failed to generate a data event
65	Master station does not generate events
66	Data manager received request for unrecognized I/O point type
67	Data recording ON/OFF operation failed

68	Data manager failed to record data recording period
69	Timer reporting PT to AT conversion failed
70	Timer reporting AT to PT conversion failed
71	Timer reporting PT of last Top Of Hour failed
72	Timer reporting failed time computation
73	Data manager was asked to set recording period too high - max limit enforced
74	Data manager was asked to set recording period too low - min limit enforced
75	Data manager failed to schedule the next data recording cycle
76	Invalid (null) buffer address
77	Analog input out of specified range (overflow)

Error Event Identifiers – DNP Data Link

100	Incoming message too long
101	Incoming message too short
102	DNP data link frame de-serialization failed
103	DNP data link frame contains incorrect number of blocks
104	DNP data link frame integrity bad
105	DNP data link frame header block has incorrect length
106	DNP data link frame header block first byte bad
107	DNP data link frame header block second byte bad
108	DNP data link frame block CRC bad
109	DNP data link frame block length bad
110	DNP data link source and destination addresses equal
111	DNP data link frame had insufficient data
112	DNP data link frame serialization failed
113	DNP data link response function (ACK, NACK, LINK_STATUS) received illegal function argument
114	DNP data link ACK not sent
115	DNP data link NACK not sent
116	DNP data link LINK_STATUS not sent
117	DNP data link RESET LINK STATE not sent
118	DNP data link RESET USER PROCESS not sent
119	DNP data link USER DATA not sent
120	DNP data link TEST REMOTE LINK not sent
121	DNP data link USER DATA WITH CONFIRM not sent
122	DNP data link function received unsupported function code request
123	DNP data link function received user data which is too long
124	DNP data link failed to receive response from a station
125	DNP data link reporting route table full

Error Event Identifiers – DNP Transport Layer

150	DNP transport layer missing a specific segment, message incomplete
151	DNP transport layer missing segment(s), message incomplete

152	DNP transport layer failed to send message to specified station address
-----	---

Error Event Identifiers – DNP Application Layer

200	DNP application layer fragment too short
201	DNP application layer received bad range specifier code
202	DNP application layer received a non-first fragment while no message was accumulating, fragment discarded
203	DNP application layer missing a specific fragment, message incomplete
204	DNP application layer missing fragment(s), message incomplete
205	DNP application layer failed to send message to outstation
206	DNP application layer received bad range (start & stop) values
207	DNP application layer fragment contains insufficient data to deserialize an object
208	DNP application layer failed to deserialize object group
209	DNP application layer received bad offset value
210	DNP application layer received bad index size value
211	DNP application layer received bad object type value
212	DNP application layer received bad function code value
213	DNP application layer failed to save object group data to this station
214	DNP application layer received message from station reporting restart
215	DNP application layer failed to arm (select) control point(s)
216	DNP application layer failed to operate control point(s)
217	DNP application layer source object size undefined
218	DNP application layer private registration object contains unknown vendor id
219	DNP application layer received bad private object registration number
220	DNP application layer object contains insufficient data
221	DNP application layer failed to execute routing management command

Source File Identifiers

0	IOBoard.lib
1	BigDig.lib
2	Timer.lib
3	Buffer.lib
4	SerialFlqashDisk.lib
5	Array.lib
6	SerialPort.lib
7	Ethernet.lib
8	CommChannel.lib
9	IOPoint.lib
10	ControlPoint.lib
11	StatusPoint.lib
12	CounterPoint.lib

13	AnalogPoint.lib
14	Config.lib
15	DataManager.lib
16	OutMsgQueItem.lib
17	OutMsgQue.lib
18	DnpCfg.lib
19	DnpStation.lib
20	DnpFrame.lib
21	DnpDataLink.lib
22	DnpSegment.lib
23	DnpTspLayer.lib
24	DnpObject.lib
25	DnpObjectGroup.lib
26	DnpFragment.lib
27	DnpAppLayer.lib
28	DnpClient.lib
29	DnpServer.lib
30	DnpI.lib
31	ThisStation.lib
32	ModbusI
33	ModbusCfg

Event Log Entry Value Types

0	None (No entry)
1	Signed 16 bit integer
2	Unsigned 16 bit integer
3	Unsigned 32 bit integer

Message Routing (Store and Forward)

Routes must be used when the master station cannot directly communicate with one or more units in the field. This can be because those units are too far, or they may be obstructed so direct line of communication is not possible, etc.

Routing is implemented in the Data Link layer over standard DNP in such a way as to remain fully compatible with DNP. DNP messages contain routing information in the N most significant bits of their destination address as part of standard DNP addressing, where N is a number between 0 (no routing) and 8. In addition, route users (see definition below) need not be units running CCDC, i.e. they can communicate with the master station via above described network using standard DNP. In other words, route users can be built by any vendor, running standard DNP, as long as they are addressed between 1 and $2^{16-N} - 1$.

When so configured, DNP slave can store and forward messages to the local DNP master, and vice versa. This capability makes NeXGen units running CCDC capable of storing and forwarding messages to neighboring units, thus forming a DNP network. This network has the following properties:

- It contains one, centrally located master station (star topology)
- Each unit can be configured as store and forward message repeater (router)
- There can be up to $(2^{**N})-1$ routes in the network, i.e. each unit can be a member of up to $(2^{**N}) - 1$ routes.
- Routes can cross, i.e. they can share arbitrary number of units.
- Units doing the routing (repeaters) need to have equal DNP master and slave addresses.







A distinction needs to be made between *route members* (store and forward repeaters), and *route users* (units communicating with the master station via above described network, but not themselves forwarding DNP messages). As far as firmware is concerned, there can be

1. Up to $(2^{**N}) - 1$ routes in a network,
2. Up to $2^{**}(16-N) - 1$ route members per route
3. Up to $2^{**}(16-N) - 1$ route users.

Practical limitations, such as timing, reduce these numbers to lower values.

APPENDIX A

Troubleshooting

Problem	Potential Cause	Suggestion	Caution Status
No LEDs active	No line power to PCB	Check the AC-IN wires in the power input terminal block at J6. Confirm AC Neutral and Hot inputs are connected	
No LEDs active	Resettable input power fuse may be tripped.	Power down the instrument. Unplug the main power. Allow the CCU to rest for approximately 20 minutes. Power-up the instrument and observe LEDs	
LEDs are active, but CLOSE and TRIP relays do not cause capacitor switch to operate	Load Fuse may be blown, or missing	Check the load fuse and replace if blown or missing	
CLOSE and TRIP relays are operating in the absence of a remote or local command	Voltage override may be enabled	Confirm the Voltage Override program setting	
CLOSE/TRIP relays are not operating with remote commands	Instrument is improperly addressed.	Check the instrument address.	
Address is correct, but CLOSE/TRIP relays are not operating with remote commands	Instrument cannot communicate through wireless transceiver	Check the instrument Rx / Tx LEDs at the transceiver connection point on the PCB. Confirm both the Rx and Tx lights are active.	

APPENDIX B

Default parameter settings matrix

Matrix Number	0	1	2	3	4	5	6	7
Protocol	TS11	TS11	TS11	TS11	TS11	TS11	TS11	TS11
Trip Function 1	FN1	FN1	FN1	FN1	FN0	FN0	FN1	FN1
Close Function 1	FN2	FN2	FN2	FN2	FN1	FN1	FN2	FN2
Trip Function 2	NA	NA	NA	NA	NA	NA	NA	NA
Close Function 2	NA	NA	NA	NA	NA	NA	NA	NA
Voltage Override Enable	NA	NA	NA	FN0	FN2	FN2	NA	NA
Voltage Override Disable	NA	NA	NA	FN3	FN3	FN3	NA	NA
Address Zero All Call Address	No	No	No	No	No	No	No	No
Close Safety Timer	7 minutes	7 minutes	7 minutes	7 minutes	5 minutes	5 minutes	7 minutes	5 minutes
Manual Close Delay	Disabled	Disabled	Disabled	60 Seconds	60 Seconds	60 Seconds	Disabled	Disabled
Manual Trip Delay	Disabled	Disabled	Disabled	Disabled	60 Seconds	60 Seconds	Disabled	Disabled
Relay Pulse Duration	10,000ms (10sec)	300ms	300ms	10,000ms (10sec)	18,000ms (18 sec)	18,000ms (18 sec)	5000ms (5sec)	10,000ms (10sec)
Local To Remote Delay	2 Minutes	2 Minutes	2 Minutes	2 Minutes	1 Minute	1 Minute	2 Minutes	2 Minutes
Voltage Override Remote Control	Disabled	Disabled	Disabled	Disabled	Enabled	Enabled	Disabled	Disabled
Voltage Override	Disabled	Disabled	Disabled	Disabled	Enabled	Enabled	Disabled	Disabled
Trip Voltage	NA	NA	NA	NA	127	127	NA	NA
Trip Release	NA	NA	NA	NA	124	125	NA	NA
Close Release	NA	NA	NA	NA	120	119	NA	NA
Close Voltage	NA	NA	NA	NA	117	117	NA	NA
Switching Delay	NA	NA	NA	NA	60 seconds	60 seconds	NA	NA

Update 7-9-15